



# Cavity Pressure Sensors

## Button Style Sensors Installation & Use Instructions

RJG, Inc.

© 2001, 2002, 2003, 2004



*March 29, 2004*

# Table of Contents

Introduction to RJG Cavity Pressure Sensors.....	1
Universal Cavity Pressure Sensor Installation	
Sensor Placement Strategy.....	2
Process Monitoring Applications.....	2
Process Control Applications.....	3
Mechanical Placement.....	4
Operating Principle.....	5
Technical Specifications.....	7
Installation & Mold Modifications	
T-412, T-413, & T-414.....	8
T-445.....	11
Appendix A: Troubleshooting	
Wiring Failure.....	14
Zero Balance.....	14
Appendix B: Calibration	
Cavity Pressure Sensors.....	15
Appendix C: Special Modifications/Applications	
Oversize Ejector Pins that Exceed the Standard Sensor Capacity Rating.....	17
Cutting a Slot Under Interfering Pins.....	17
Non-Moving Ejector Pins.....	18
Utilizing Ejector Pins of 1/16" Diameter or Less.....	18
Multiple Ejector Pin Placement Above a Sensor.....	19
Appendix D: Mounting the Bendix Connector.....	20
Appendix E: Retaining the Sensor Cable.....	22
Appendix F: Multiple Sensors in a Slot.....	23
Sensor Selection Table.....	24
RJG Product Disclaimer.....	25

# List of Illustrations

Figure 1	Monitoring One Cavity in Each Zone.....	3
Figure 2	Typical Knit Line.....	3
Figure 3	Area of Influence in a Cavity.....	3
Figure 4	Strain Gauge Operating Principle.....	5
Figure 5	Cavity Pressure & the Ejector Pin .....	5
Figure 6	Sensor Length Reference.....	7
Figure 7	T-412, T-413 & T-414 Button Style Sensor Dimensions.....	9
Figure 8	Recommended Mold Cutout for T-412, T-413, & T-414 Sensor.....	9
Figure 9	Recessed Mounting of the T-412, T-413, & T-414.....	10
Figure 10	T-445 Button Style Sensor Dimensions.....	12
Figure 11	Recommended Mold Cutout for T-445 Sensor.....	12
Figure 12	Recessed Mounting of the T-445.....	13
Figure 13	Pin Out Schematic.....	14
Figure 14	Welded-in Ejector Sleeve Replacement.....	17
Figure 15	Cutting a Slot Under Interfering Pins.....	17
Figure 16	Utilizing Non-Moving Pins.....	18
Figure 17	Utilizing Ejector Pins of 1/16” Diameter or Less.....	18
Figure 18	Multiple Ejector Pin Placement Above a Sensor.....	19
Figure 19	Connector Mounting Option.....	20
Figure 20	“L” Style Mounting Block.....	21
Figure 21	“H” Style Mounting Block.....	21
Figure 22	Retaining the Sensor Cable.....	22
Figure 23	Multiple Sensors in a Slot.....	23
Table 1	Button Style Expected Pressures.....	6
Table 2	Button Style Sensor Dimensions.....	7
Table 3	Technical Specifications.....	7
Table 4	Resistance Readings.....	14
Table 5	Pin Assignment.....	14
Table 6	Ejector Pin & Sensor Calibration Table.....	15
Table 7	Sensor Calibration Factors.....	16
Table 8	Sensor Calibration Formulas.....	16

# RJG Cavity Pressure Sensors

## *Introduction*

RJG, Inc. Cavity Pressure Sensors assist in providing accurate sensor-based Statistical Process Control (SPC) and are also rugged and reliable.

The Button style sensor (T-412, T-413, T-414, and T-445) has a flexible cable with a brazed stem at the body and a strain-relieved connector. RJG's largest sensor is the T-445: its diameter measures 0.625".

# Universal Cavity Pressure Sensor Installation

To ensure the successful application of cavity pressure monitoring and control technology, it is vitally important that sensors be installed properly. Proper installation requires two (2) fundamental things. First, the sensor should be located in the correct region of the cavity so that proper information will be obtained. Secondly, the mechanical installation must be done properly to ensure that the sensor can be installed and removed and that it will not have pre-loads, side loads, or other mechanical impediments to the successful detection of the pressure in the cavity.

## Sensor Placement Strategy

The strategy for locating the sensor will be different depending on whether your primary goal is process monitoring or process control.

### Process Monitoring Applications:

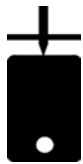

If the sensor is primarily going to be used for monitoring rather than control, the end-of-cavity is the best location. This specifically applies to accomplishing SPC, predicting good vs. bad parts, correlating cavity pressure to part conditions, or simply detecting non-fills (short shots). This location will show the maximum amount of variation of in-cavity pressure and act as a “catch-all” for the process to detect change. A good way to find the sensing location at the end-of-cavity is to make a shot approximately 10% short by reducing the injection stroke and turning off 2nd stage pressure. The sensor can be placed beneath a pin (or flush with the cavity) in the unfilled region.



If the pressure drop across the cavity is to be detected or if the maximum amount of information is to be obtained using sensors, a sensor near the gate, in conjunction with one at the end of the cavity, will provide optimum capability. This will allow monitoring of the degree of packing across the entire part, as well as an estimate of average cavity pressure. It will also provide the maximum ability to monitor part quality.

In multiple cavity tools with cold runner systems, monitoring of one or two cavities will generally allow the prediction of quality in the other cavities. This assumes that proper attention is paid to mold balance, mold deflection, and mold temperature control so that each cavity is influenced in an identical fashion. It is easier to predict part quality in a balanced mold than an unbalanced mold. If an unbalanced runner system is used, installing a sensor in the first and last cavities to fill will usually be sufficient for monitoring purposes in most applications.

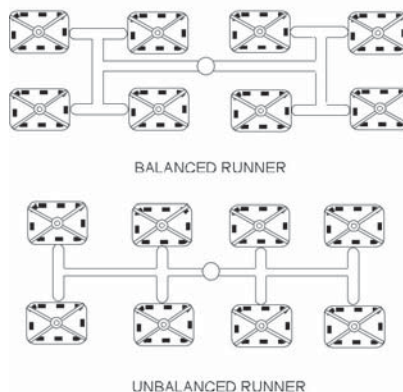

Hot runner molds are different because the temperature of the tips often varies over time so the balance is rarely consistent. This means that monitoring of one cavity will not necessarily predict quality in other cavities; therefore, more sensors are required for monitoring. If monitoring of all cavities is not practical, you can monitor one cavity in each zone instead (See Figure 1). Alternatively, you can identify problematic cavities and only monitor these. In single parts with multiple drops, the last point to fill beneath each drop should be monitored for maximum quality monitoring effectiveness (See Figure 2).

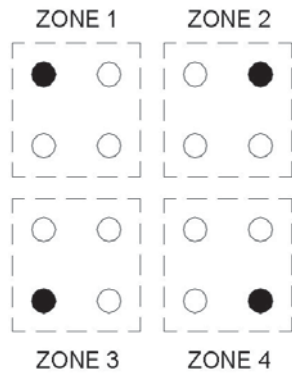

**Figure 1:** Monitoring One Cavity in Each Zone

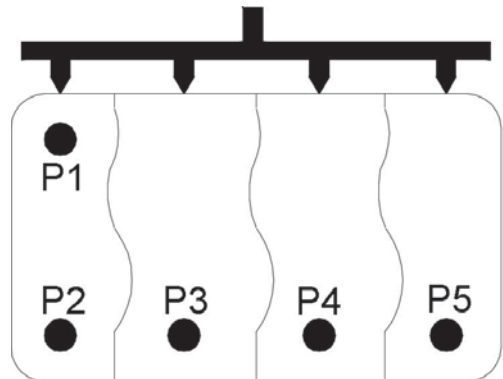

**Figure 2:** Typical Knit Line: Pressure Measurement in Single Cavity Multiple Gate Runnerless Systems

**NOTE:** In hot runner applications, if there is any question, contact RJG Customer Support for assistance before locating sensors in the mold.

Process Control Applications:



If control of the molding machine is the primary reason for the implementation of cavity pressure sensing or if flashed parts or gate seal/non-seal is always to be detected, placing the cavity pressure sensor near the gate end of the part inside the cavity is correct. RJG strongly recommends that end-of-cavity locations be avoided for control as the machine cannot react fast enough to use this for control.

Control sensors should be located in the “Area of Influence”. This is the region of the part where the last material was flowing. An easy way to find the Area of Influence is to change from a translucent material to a colored material. The region where the first color appears is in the Area of Influence (See Figure 3).

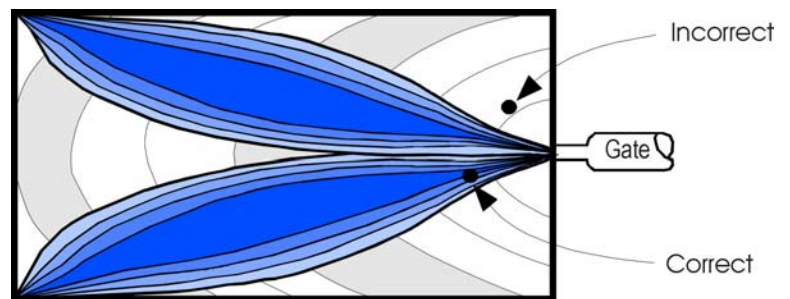

**Figure 3:** Area of Influence in a Cavity

## Mechanical Placement

Sensor placement in an injection mold should, whenever possible, be behind a moving ejector pin that is actually used to eject the part. This is always preferable to one which is stationary as the ejection movement will remove residue around the pin, minimizing friction. This is especially true in thermoset applications and when sensing thermoplastic materials that give off gases such as vinyl, acetyl, etc. (NOTE: *Does not apply to Flush Mount sensors*)

A sensor located behind a moving ejector pin will be able to sense and measure the force required to eject the part out of the mold.

The pin used must fully contact plastic in the mold runner or cavity and not contact or “kiss off” on mold steel in such a way as to impart a pre-load and cause false readings. The location of the sensor in the cavity is determined by the primary use of the sensor, as outlined previously.

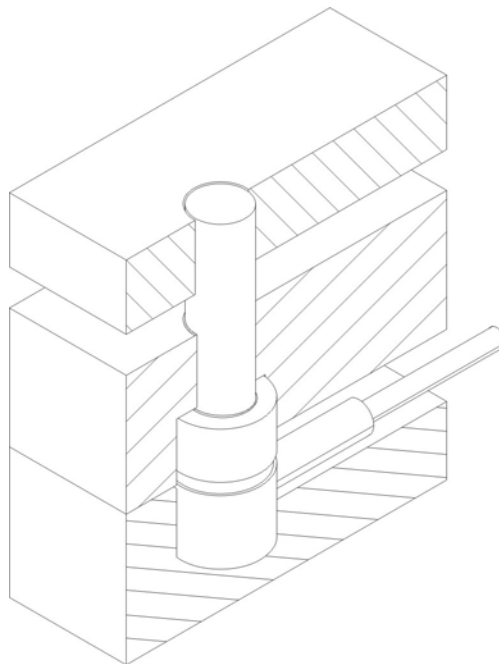

# Operating Principle

RJG's strain gauge-based design sensors are configured in a Wheatstone bridge, which converts mechanical energy into electrical energy. Strain gauges operate on the principle that the resistance of a wire changes as pressure on the wire changes (See Figure 4).

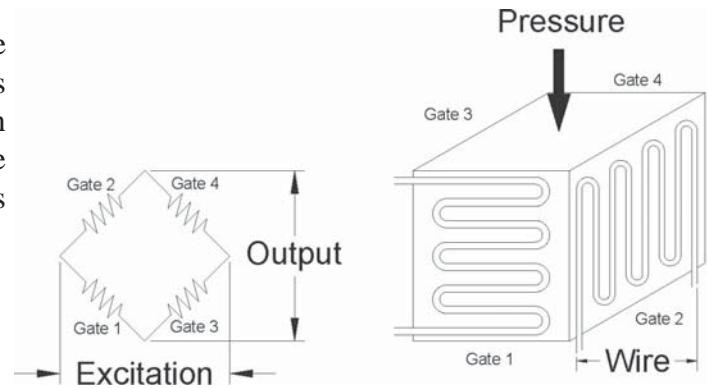

Figure 4: Strain Gauge Operating Principle

For indirect sensors, cavity pressure causes the ejector pin to force itself against the sensor which rests behind the head of the pin in the ejector plate, as shown in Figure 5. The sensor generates a low-level voltage signal that is proportional to the amount of deflection caused from the pin being put under pressure. This output voltage signal, when calibrated, directly correlates with the pressure in the cavity.

NOTE: Any sensor requires a signal conditioner to display the pressure it is seeing.

## Ejector Pin Sizes

The size of the ejector pin impacts the amount of force applied. Therefore, the sensors are rated in terms of force (lb) rather than pressure. For a full scale pressure of 20000 psi in a mold, the amount of force on the sensor can be determined as follows:

$$F = \frac{20000 \text{ psi} * \pi D^2}{4}$$

(D is the diameter of the ejector pin and  $\pi = 3.1416$ .)

Example: With a 1/8" pin, the force on the sensor equals 245 lb for a 20000 psi full scale pressure. This 245 lb is roughly half of the full scale rated load of the Model T-412 sensor (500 lb) yielding a rugged application.

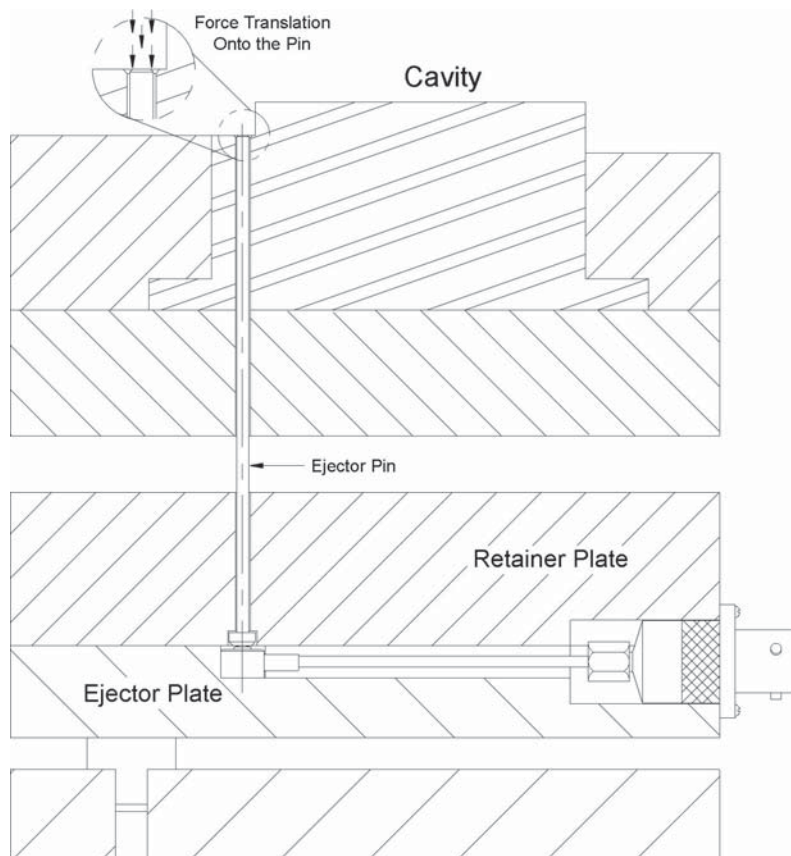

Figure 5: Cavity Pressure and the Ejector Pin

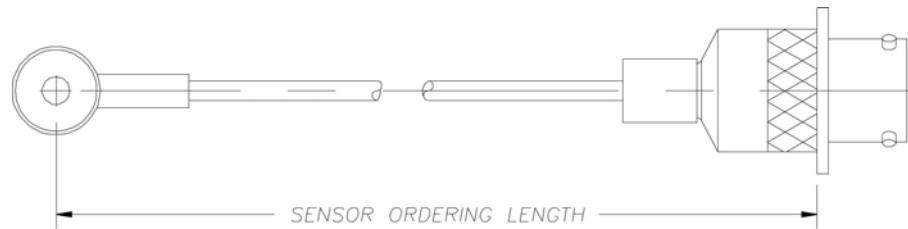

Table 1 lists full scale pressures for some common pin sizes.

Pin Size	Sensor	Full Scale Pressure
1/16"	T-414	40744 psi
3/32"	T-414	18108 psi
3/32"	T-412	72433 psi
1/8"	T-412	40744 psi
5/32"	T-412	26076 psi
3/16"	T-412	18108 psi
3/16"	T-413	72433 psi
1/4"	T-413	40744 psi
5/16"	T-413	26076 psi
3/8"	T-413	18108 psi
3/8"	T-445	36217 psi
7/16"	T-445	26608 psi
1/2"	T-445	20372 psi
9/16"	T-445	16096 psi
5/8"	T-445	13038 psi
3/4"	T-445	9054 psi

*Table 1: Button Style Expected Pressures*

# Technical Specifications



**Figure 6: Sensor Length Reference**

Sensor	Body Diameter	Body Height	Length*
T-414, T-412, T-413	0.500"	0.375"	12", 24", 36", 48"
T-445	0.625"	0.500"	

**Table 2: Button Style Sensor Dimensions**

\*Lengths over 48" require special ordering

Force Range (Overload Capacity)	
T-414.....	125 lb (187.5 lb)
T-412.....	500 lb (750 lb)
T-413.....	2000 lb (3000 lb)
T-445.....	4000 lb (6000 lb)
Maximum Temperature - Sensor.....	250°F [121°C]
Maximum Temperature - Sensor (-H suffix).....	425°F [218°C]
Maximum Temperature - Connector.....	140°F [60°C]
Temp. Comp.of Zero & Sensitivity Accuracy.....	2% F.S./100°F [38°C]
Accuracy.....	1% FS (T-9211 - 2%)
Repeatability.....	0.1% of Output
Sensitivity mV/V @ Rated Load*	
T-414, T-412, T-413, T-445.....	2.0 mV/V
Std. Connector.....	Bendix PTO2E-10-6S, or equivalent

**Table 3: Technical Specifications**

\*Special calibrations on request

# Installation & Mold Modifications

## Standard Button (T-412, T-413 & T-414) Sensors

1. Select appropriate moving ejector pin locations with respect to the part.
2. Provide ejector plate pocket and slot dimensions. Remember, loose is better!
  - a. Machine a 0.250" wide by 0.375" deep slot in the ejector plate for the cable and a 0.510" diameter pocket for the sensor head. The pocket must be centered under the selected ejector pin (See Figure 8).
  - b. Counterbore the retainer plate to relieve the head of the ejector pin by 0.010" to eliminate a potential pre-load on the sensor when installed (See Figure 8).
  - c. Counterbore the ejector plate by 0.020" to allow the head of the pin to clear the plate and only rest on the sensor when under pressure (See Figure 8).
  - d. Prepare a pocket in the edge of the plate to recess the sensor connector for protection. The pocket must be large enough to allow the connection/disconnection of the cable when setting and removing the mold from the press (See Figure 9).
  - e. If the sensor cable must be bent to accommodate obstacles in the mold, there must be a 1.50" minimum clearance (from the center of the button towards the connector end) before the cable can be bent. This will ensure that the wires will not be pulled out of the button (See Figure 9).

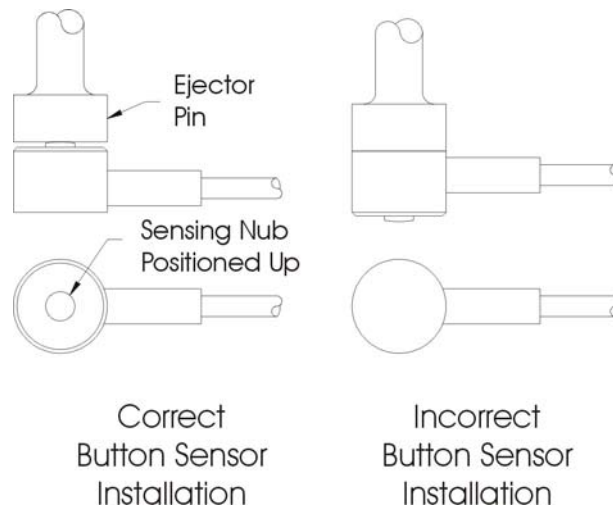

**NOTE:** *If the sensor's cable becomes damaged during installation or on subsequent production runs, whereas the cable wires are accidentally cut or pulled out of the sensor body or connector, **DO NOT** try to re-solder the wires back together at your facility. Instead, send the sensor back to RJG to have the wires re-soldered and the sensor re-calibrated. Splicing and soldering a damaged cable may cause calibration errors.*

Dimensions for the T-412, T-413, and T-414 can be referenced in Figure 7. The length of the Button sensor is measured from the bottom of the connector flange to the center of the button as shown below. The sensors' standard lengths are listed in Table 2.

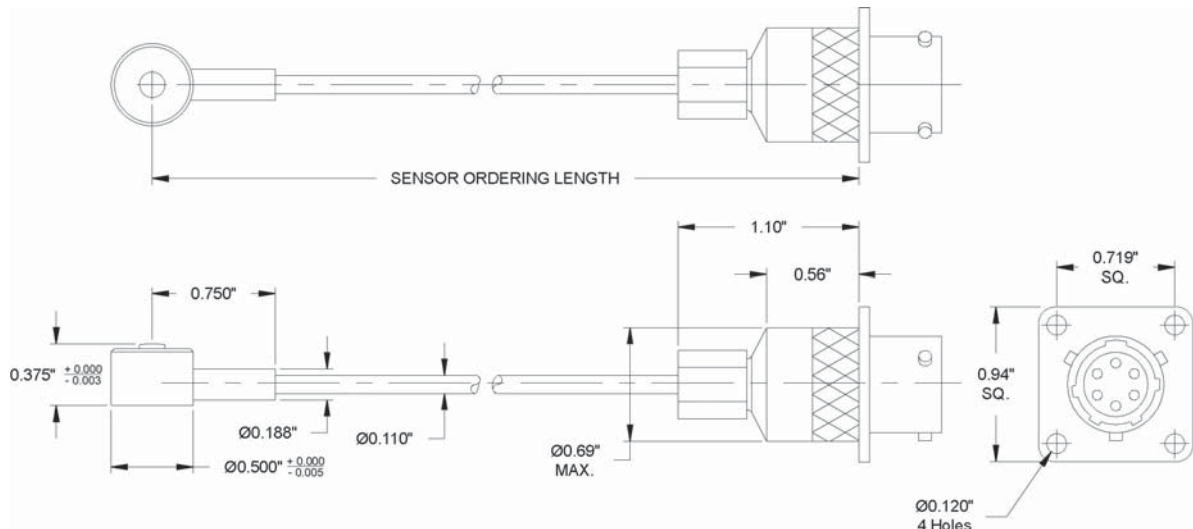

**Figure 7: T-412, T-413, & T-414 Button Style Sensor Dimensions**

Figure 8 shows the recommended mold cutout for installation of the T-412, T-413, and T-414.

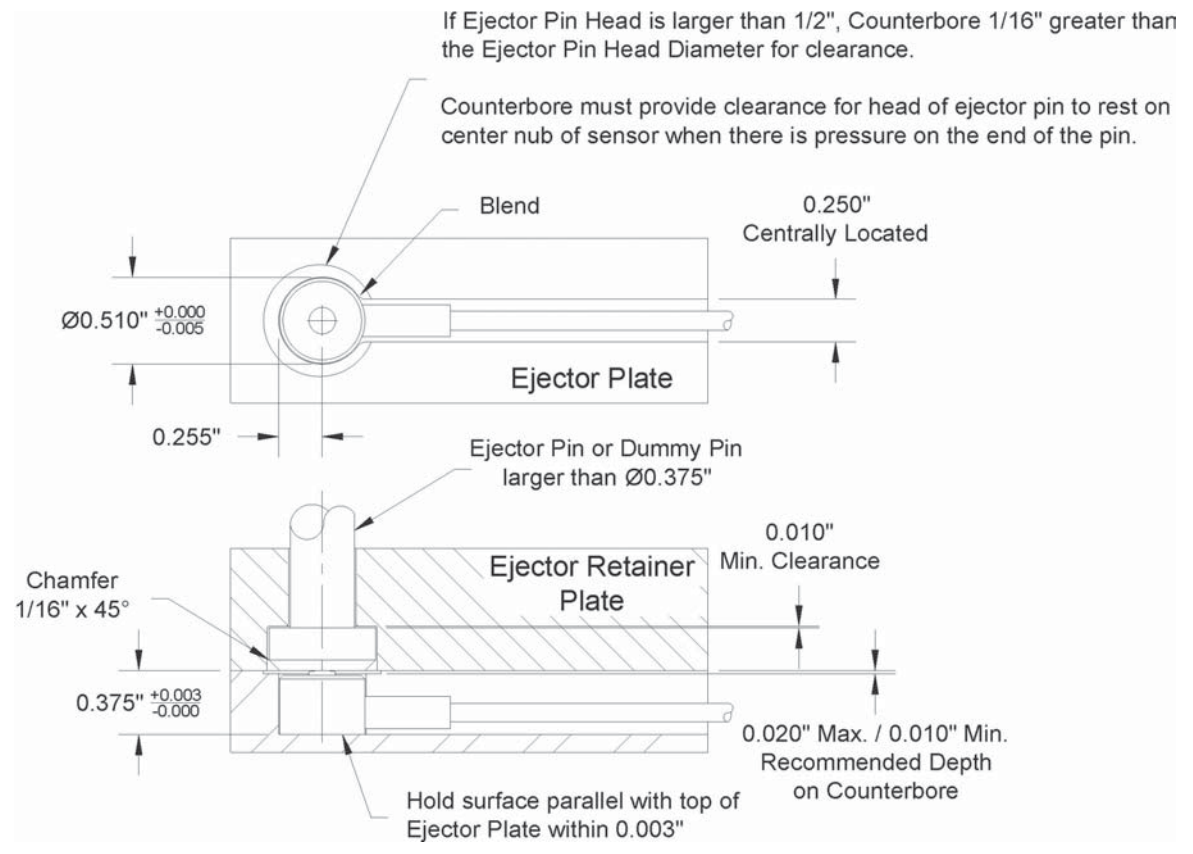

**Figure 8: Recommended Mold Cutout for T-412, T-413, & T-414 Sensor**

Figure 9 outlines the dimensions when inserting the T-412, T-413, or T-414 into an ejector plate.

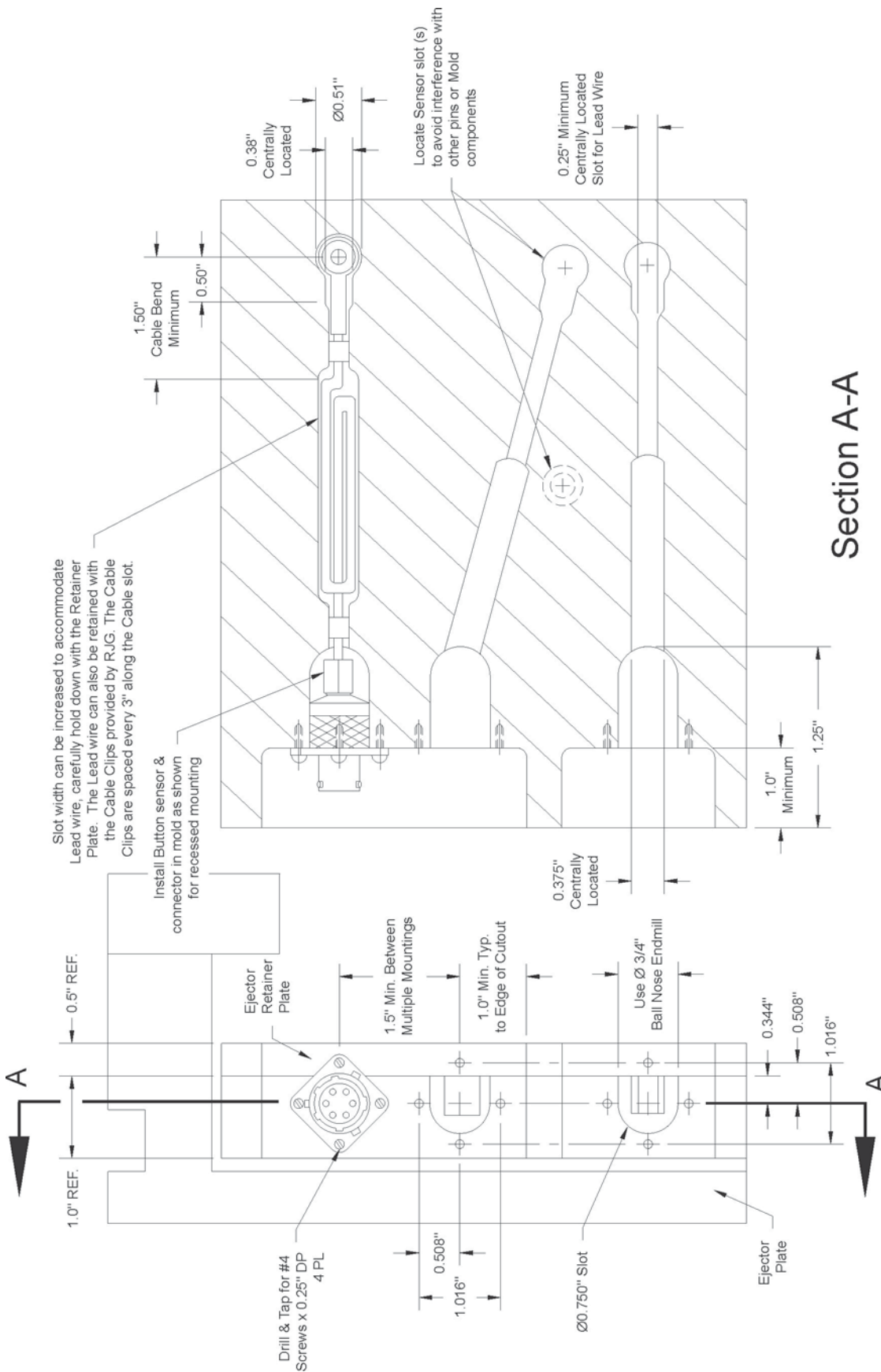

Figure 9: Recessed Mounting of the T-412, T-413 & T-414

NOTE: Connector flange is rotated 45° to allow clearance of 3/4" ball nose endmill slot between the hole patterns

NOTE: When the ejector plate is thicker than 1", the connector may be centered on the plate's thickness. Alter the mounting dimension as required. The slot for the lead wire should be deepened as it approaches the connector end as required.

# Installation & Mold Modifications

## Big Button (T-445) Sensor

1. Select appropriate moving ejector pin locations with respect to the part.
2. Provide ejector plate pocket and slot dimensions. Remember, loose is better!
  - a. Machine a 0.250" wide by 0.500" deep slot in the ejector plate for the cable and a 0.635" diameter pocket for the sensor head. The pocket must be centered under the selected ejector pin (See Figure 11).
  - b. Counterbore the retainer plate to relieve the head of the ejector pin by 0.010" to eliminate a potential pre-load on the sensor when installed (See Figure 11).
  - c. Counterbore the ejector plate by 0.020" to allow the head of the pin to clear the plate and only rest on the sensor when under pressure (See Figure 11).
  - d. Prepare a pocket in the edge of the plate to recess the sensor connector for protection. The pocket must be large enough to allow the connection/disconnection of the cable when setting and removing the mold from the press (See Figure 12).
  - e. If the sensor cable must be bent to accommodate obstacles in the mold, there must be a 1.50" minimum clearance (from the center of the button towards the connector end) before the cable can be bent. This will ensure that the wires will not be pulled out of the button (See Figure 12).

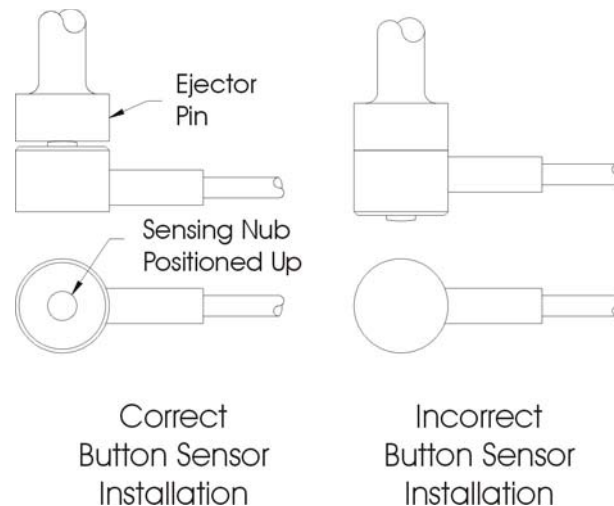

**NOTE:** *If the sensor's cable becomes damaged during installation or on subsequent production runs, whereas the cable wires are accidentally cut or pulled out of the sensor body or connector, **DO NOT** try to re-solder the wires back together at your facility. Instead, send the sensor back to RJG to have the wires re-soldered and the sensor re-calibrated. Splicing and soldering a damaged cable may cause calibration errors.*

Dimensions for the T-445 can be referenced in Figure 10. The length of the Button sensor is measured from the bottom of the connector flange to the center of the button as shown below. The sensors' standard lengths are listed in Table 2.

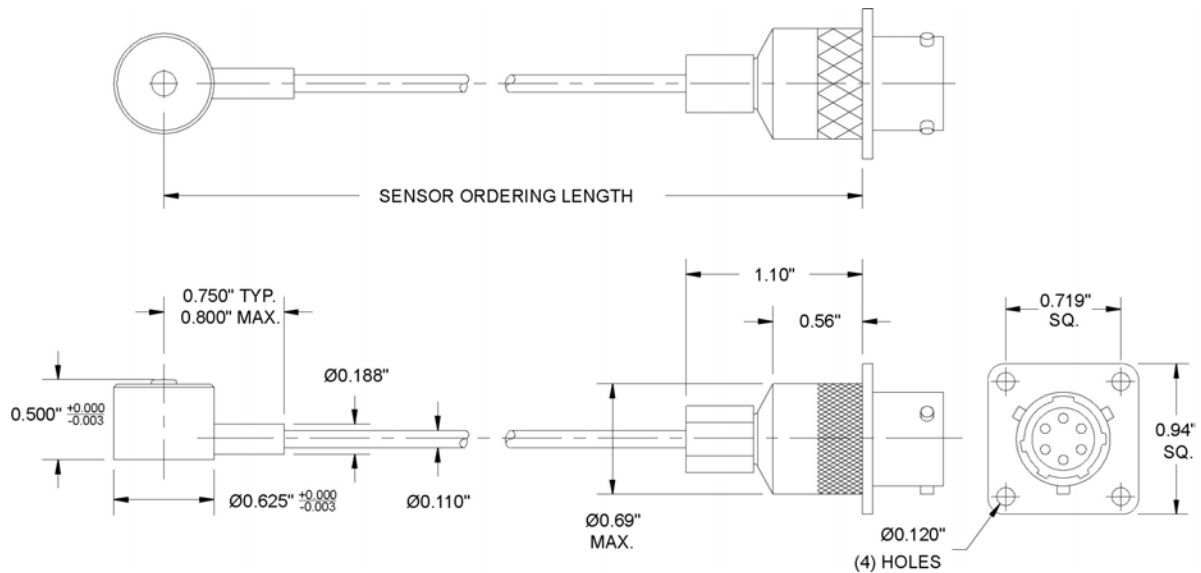

**Figure 10: T-445 Button Style Sensor Dimensions**

Figure 11 shows the recommended mold cutout for installation of the T-445.

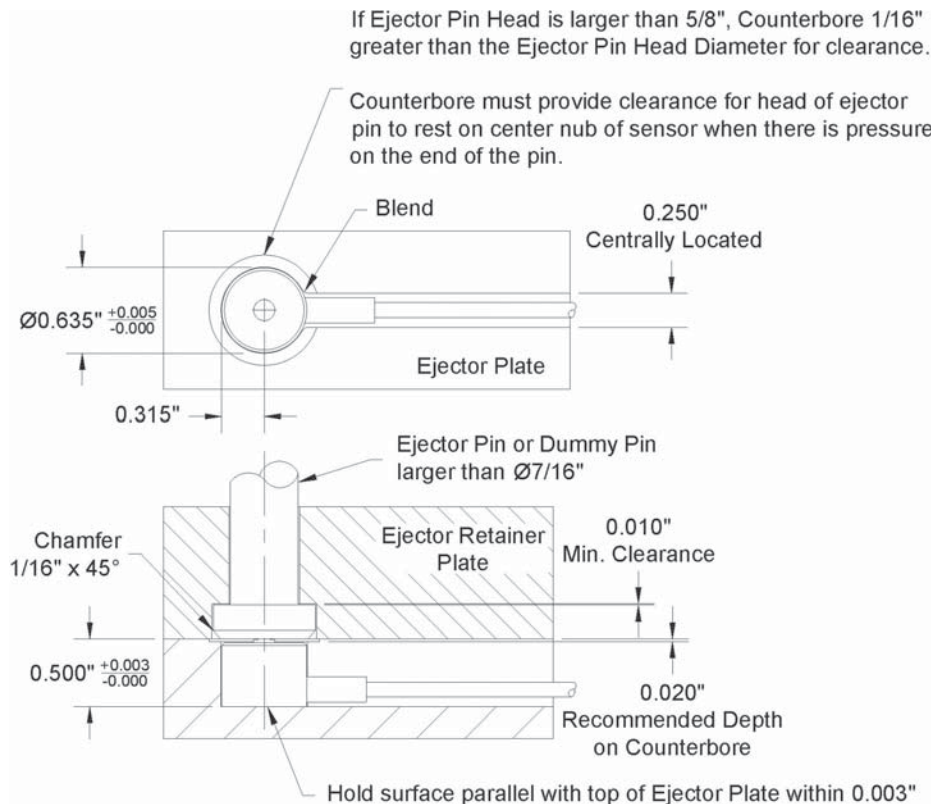

**Figure 11: Recommended Mold Cutout for T-445 Sensor**

Figure 12 outlines the dimensions when inserting the T-445 into an ejector plate.



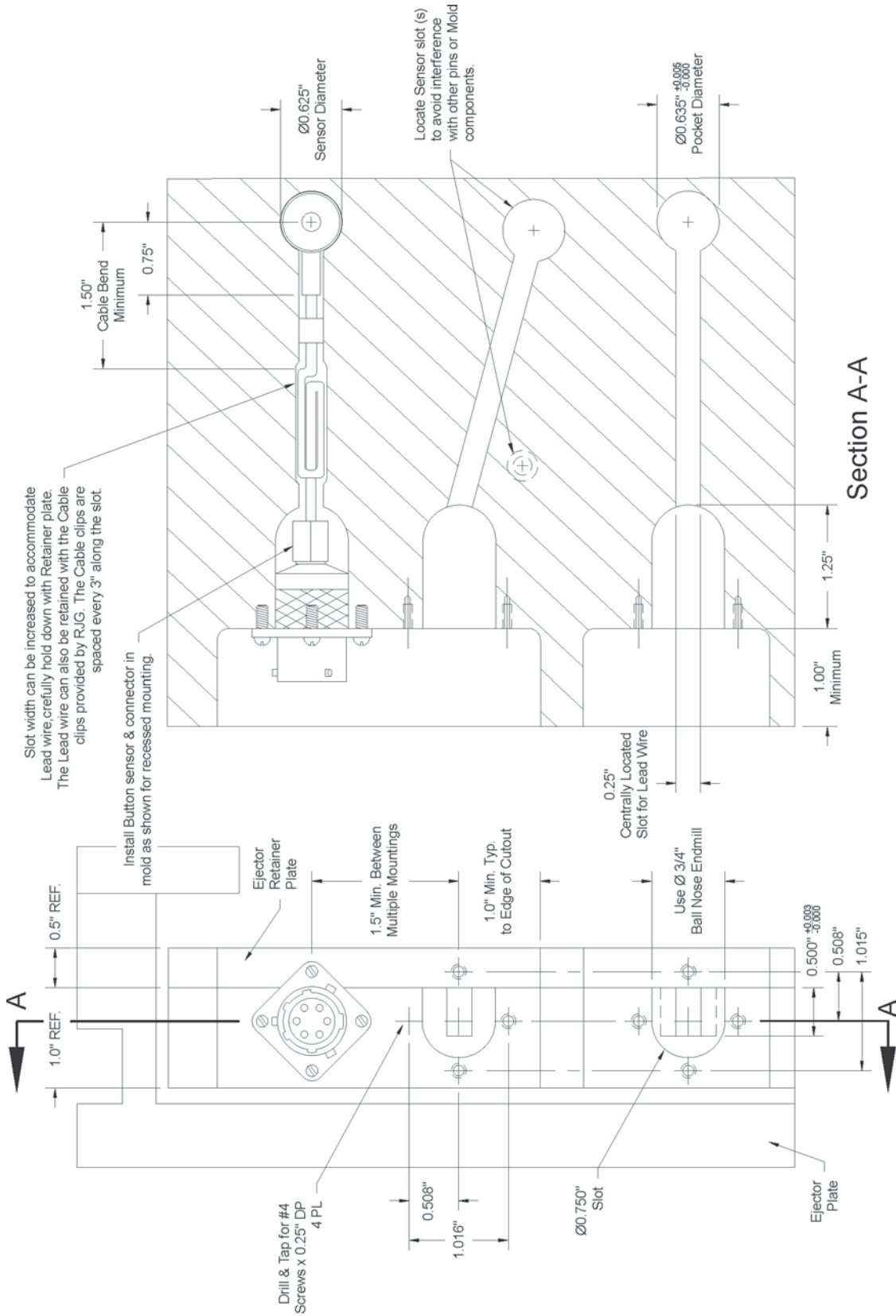

Figure 12 Recessed Mounting of the T-445

NOTE: Connector flange is rotated 45° to allow clearance of 3/4" ball nose endmill slot between the hole patterns

NOTE: When the ejector plate is thicker than 1", the connector may be centered on the plate's thickness. Alter the mounting dimension as required. The slot for the lead wire should be deepened as it approaches the connector end as required.



# Appendix A - Troubleshooting

## Wiring Failure

The most common causes of sensor failures are short circuits or broken wires. Refer to Appendix E - *Retaining the Sensor Cable* on page 22 for preventing cable wire failures. The following approximate resistances can be measured to determine if a sensor is good.

Pin A to Pin C	260Ω to 365Ω
Pin B to Pin D	260Ω to 365Ω
Pin B to Pin C	260Ω to 365Ω
Pin A to Pin B	350Ω to 550Ω
Pin A to Pin D	260Ω to 365Ω
Pin C to Pin D	350Ω ± 5Ω

**Table 4: Resistance Readings**

Pin	Gray cable color code	Yellow cable color code
A	orange/white	black
B	blue/white	white
C	white/orange	blue
D	white/blue	brown
E	drain	drain

**Table 5: Pin Assignment**

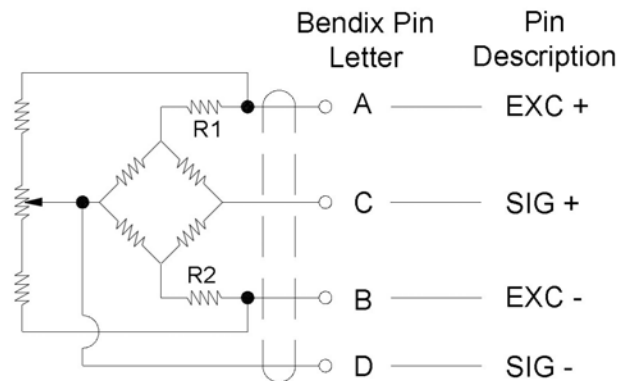

**Figure 13: Pin Out Schematic**

## Zero Balance

Though precisely balanced at the factory for a zero output when no pressure is applied to the sensor, occasionally the zero shows a shift or offset when in the cavity. This offset can be a negative (-) or positive (+) output. If too negative (-) of a reading occurs in the cavity, but not when out of the cavity, the slot has been machined too tight and the tool needs to be re-machined to 0.505” +0.005”/-0.000”. If the zero shift is too positive (+) when in the cavity, but not when out of the cavity, there is an undesirable pre-load on the sensor. Examine mold/slot area to determine the cause.

## Appendix B - Calibration

### Cavity Pressure Sensors

All RJG cavity pressure sensors are normalized to the same output and performance criteria. Based on this principle, it is possible to establish a table of calibration numbers to correspond with varying sizes of ejector pins that the cavity pressure sensor is to be used with. See Table 6 for common pin sizes. To calculate a calibration number not listed, refer to Tables 7 and 8 on the following page.

If using the sensor with the RJG Model 3015 Signal Conditioner, simple calibration checks by the operator can be made since the unit displays the CAL number desired and allows for the readjustment of any discrepancies.

If using a RJG DARTScanner™ or eDART™, this is automatically done for you.

NOTE: *RJG, Inc. recommends sending your sensor back once a year for recalibration.*

Ejector Pin	Sensor	3015 CAL # (psi)
1/16" 3/32"	T-410/T414 (125 lb)	8905 3958
1/16" 3/32" 1/8" 5/32" 3/16" 1/4"	T-405/T-412/T-425 (500 lb)	3562* 15831 8905 5699 3958 2226
3/16" 1/4" 5/16" 3/8"	T-406/T-413/T-426 (2000 lb)	15831 8905 5699 3958
3/8" 7/16" 1/2" 9/16" 5/8" 3/4"	T-445 (4000 lb)	7916 5816 4453 3518 2850 1979

**Table 6:** Ejector Pin & Sensor Calibration Table

\*Display will read  $PSI \div 10$

Sensor(s)	Weight (lb)	CAL divisor	Shunt Cal Factor
T-410, T-414	125	27.320	0.21856
T-405, T-412, T-425	500	109.280	0.21856
T-406, T-413, T-426	2000	437.120	0.21856
T-445	4000	874.240	0.21856

*Table 7: Sensor Calibration Factors*

<b>English units formula</b>	<b>Cal Number</b> = Cal Divisor ÷ Pin Area
<b>General formula</b>	<b>Cal Number</b> = [(Fullscale Force) ÷ (Pin Area)] x (Shunt Cal Factor)
<b>Area</b>	<b>Round Pin Area</b> = 0.785398 * (Diameter <sup>2</sup> )

*Table 8: Sensor Calibration Formulas*

## Oversize Ejector Pins that Exceed the Standard Sensor Capacity Rating

In large parts, at times, only large ejector pins are available. Unfortunately, mold pressure applied to a very large pin results in a very large force on the sensor, which could possibly exceed full scale force ratings. For example: 10000 psi on a 3/4" pin gives 4418 lb of force. Since the largest capacity sensor (T-445) is rated at 4000 lb, the sensor in this application may be damaged. To accomplish the use of the standard sensor, a large pin could be replaced with an ejector sleeve of the same size welded into place, and a smaller pin may be allowed to eject through the sleeve, as shown in Figure 14. As long as the loss in ejection capability is not a concern, the smaller pin allows a smaller force to be placed on the sensor for the same given mold pressure.

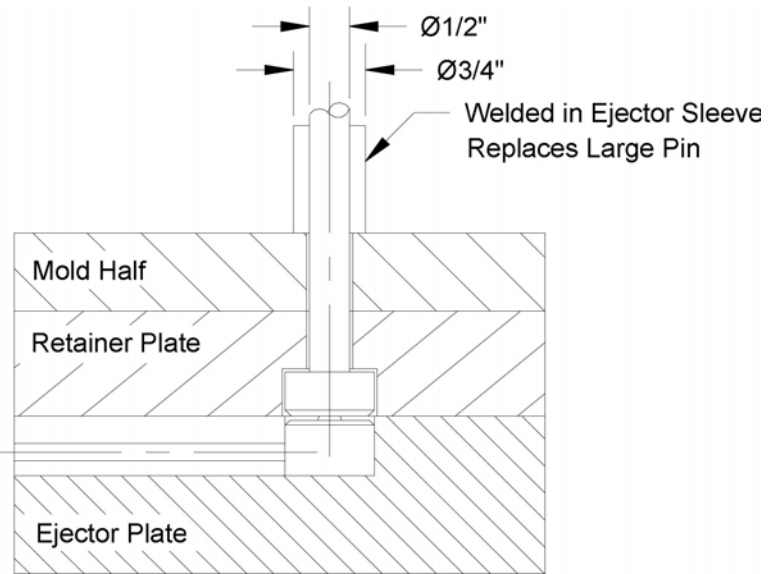

Figure 14: Welded-in Ejector Sleeve Replacement

Compared to the example above, 10000 psi on a 1/2" pin now gives 1962 lb of force within the T-413 rating.

## Cutting a Slot Under Interfering Pins

Figure 15 shows multiple pins surrounding the head of the selected sensing pin preventing full slot width clearance. The slot can be safely cut under the surrounding heads as long as enough of the remaining ejector plate surface contacts the surrounding pins' heads to cleanly eject the part without "cocking", jamming, or bending the pin.

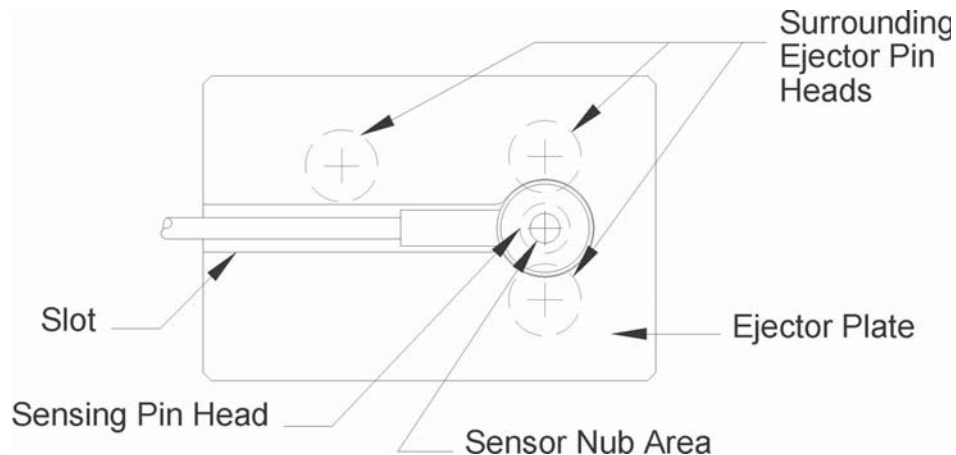
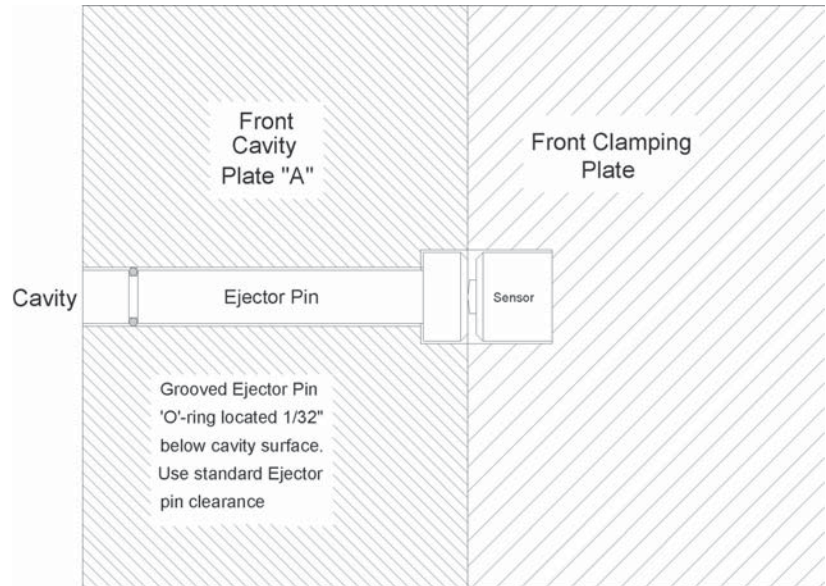

Figure 15: Cutting a Slot Under Interfering Pins

## Non-Moving Ejector Pins

Moving ejector pins are always recommended to sense pressure because of their self-cleaning feature on each shot. This prevents gases from building up around the pin and ensures repeatable force translation. In some situations, a non-moving pin must be utilized in the absence of an existing moving ejector pin. Figure 16 shows the recommended method for ensuring repeatable results from a “dead” pin. An O-Ring groove is placed in the pin 1/32” down from the cavity. An O-Ring located as close to the cavity as possible prevents gases from building around the pin clearance while still allowing proper force translation onto the sensor. Most thermoplastic applications allow use of a standard O-Ring and standard pin clearances. Thermosets and materials requiring high mold temperatures may require high temperature silicon O-Rings. Optimally, a sensor signal conditioner and autozeroing capability should be utilized in this application. At the start of injection, if any pre-load exists on the sensor, autozero will null out that error prior to pressure measurement to ensure repeatable readings.

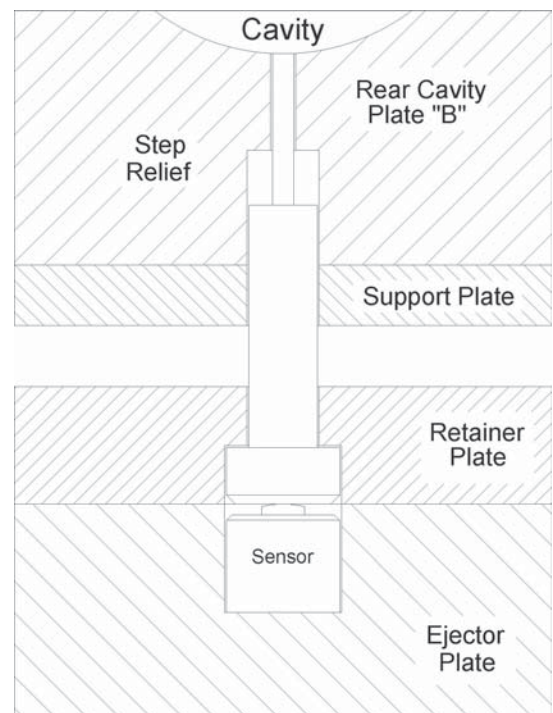

*Figure 16: Utilizing Non-Moving Pins*

## Utilizing Ejector Pins of 1/16” Diameter or Less

Sensing pressure by means of force on a pin is most reliably accomplished with pins of 1/16” diameter and greater. Unfortunately, some tools or parts are constrained by physical limitations requiring very small pins. These situations, however, still allow monitoring of mold cavity pressure via the pin.

For optimum reliability and repeatability, Figure 17 shows a method of using a modified ejector pin application. A standard 1/8” or 1/4” pin can be stepped down to the desired diameter at the cavity. The reduced diameter must be long enough to allow full travel of the ejector pin in the relief. The pin must be hardened for wear resistance. Special pins can be ordered from D-M-E or specialty pin manufactures. This provides for a larger, heavier sensing pin **not** conducive to bending under large forces.



*Figure 17: Utilizing Ejector Pins of 1/16” Diameter or Less*

## Multiple Ejector Pin Placement Above a Sensor

This option allows you to utilize an ejector pin for data collection and/or control when your mold has multiple ejector pins positioned together in a very small area. It is next to impossible to place a sensor under one of the ejector pin's head when the ejector pins are so close to each other. With this option, a cover plate is mounted under the ejector pins with one hole drilled into it, which allows one ejector pin to be in contact with the sensor. The cover plate's dimensions may vary according to the number of ejector pins in the immediate area, but the plate must be larger than the cutout needed for the sensor body and it must be recessed and flush with the ejector plate. The cover plate should be mounted with four (4) screws. These screws should not be in contact with the ejector pins, since constant pressure on the ejector pins could cause the screws to break.

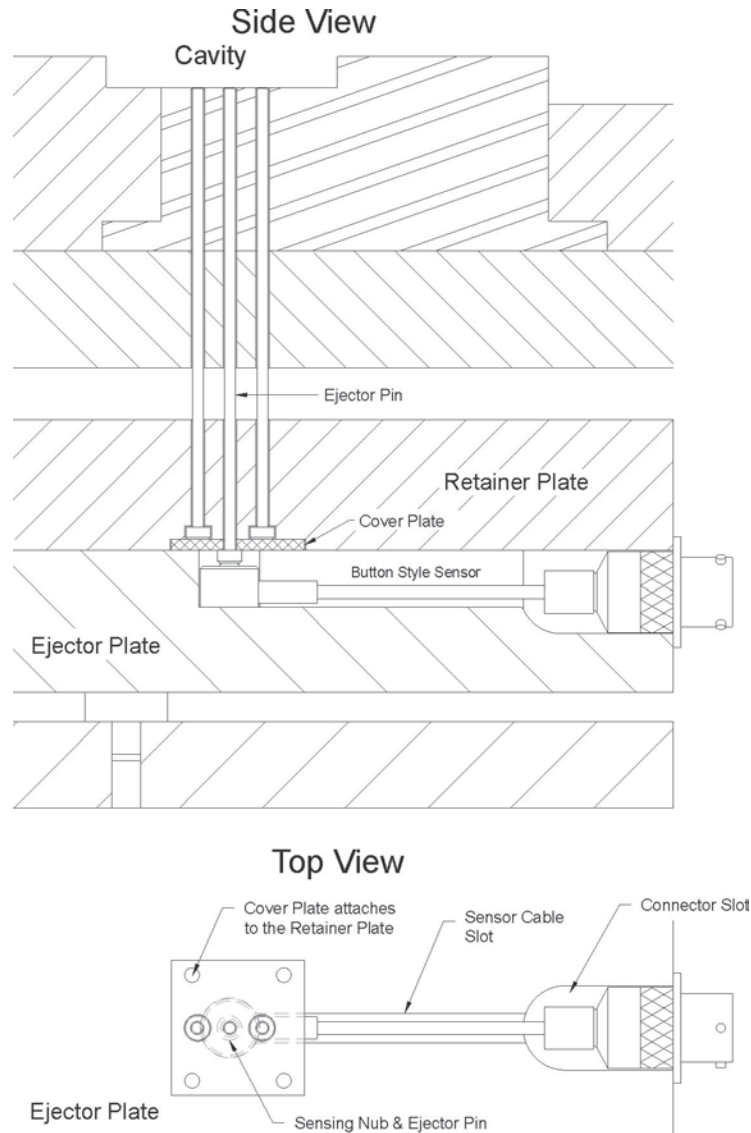

**Figure 18:** Multiple Ejector Pin Placement Above a Sensor



# Appendix D - Mounting the Bendix Connector

The Bendix connector on the sensor can be mounted with our “L” Style (MA-6157-BLK) or “H” Style (MA-MPTH-BLK) mounting blocks or directly to the mold. For installations where the Bendix connector might be exposed to temperatures above 140°F, **always use our mounting blocks**, which have a ceramic insulating strip between the mounting block and the mold. The electronics in the Bendix connectors are not rated for temperatures above 140°F. See Figure 20 for the installation of the “L” Style mounting block and Figure 21 for the installation of the “H” Style mounting block.

Figure 19 shows a connector mounting block option.

**NOTE:** *The cable does not disconnect at the sensor body.*

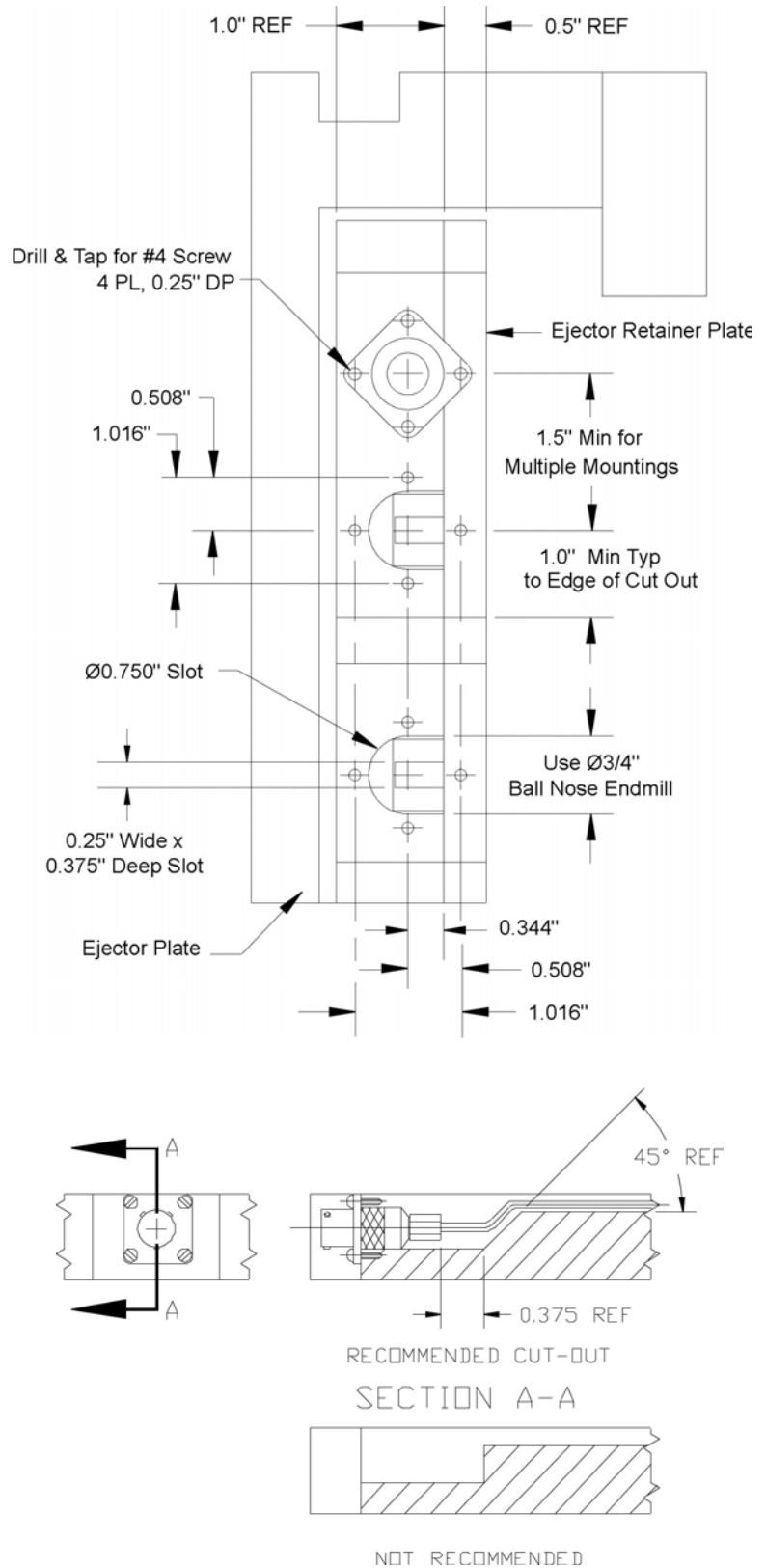

**Figure 19:** Connector Block Mounting Option

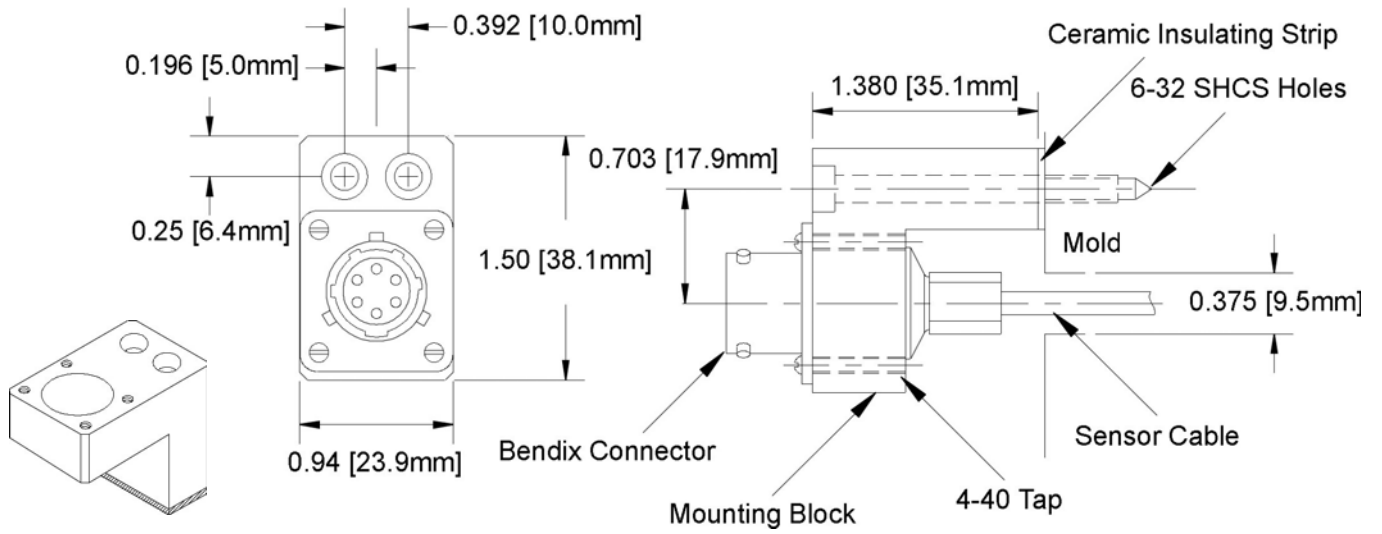

**Figure 20: "L" Style Mounting Block**

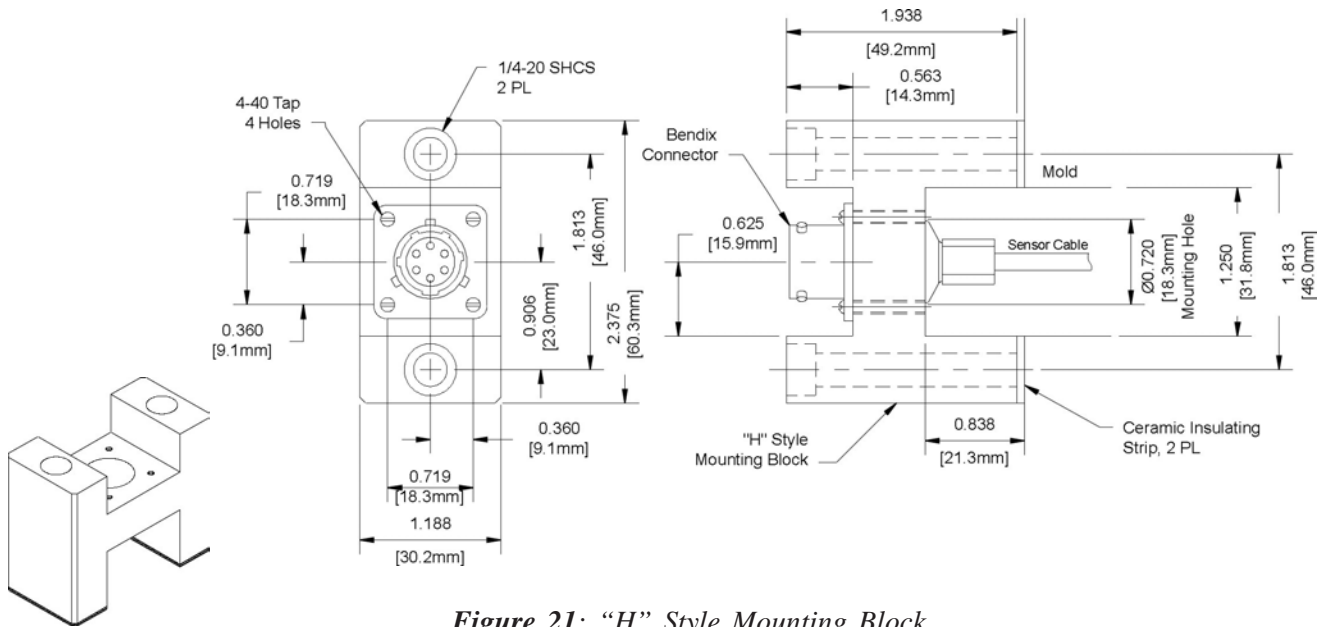

**Figure 21: "H" Style Mounting Block**



## Appendix E - Retaining the Sensor Cable

### At the Platen

The sensor cable, which goes from the pressure sensor connector to the associated instrumentation should be retained to prevent damage over time. The cable should not be left dangling from the sensor connector. The cable should be strain-relieved to the ejector/retainer plate so the cable and the sensor move as a complete assembly. There should be no movement between the cable plug and the sensor mating connector as it may have a tendency to wear on the connector insert causing premature failure.

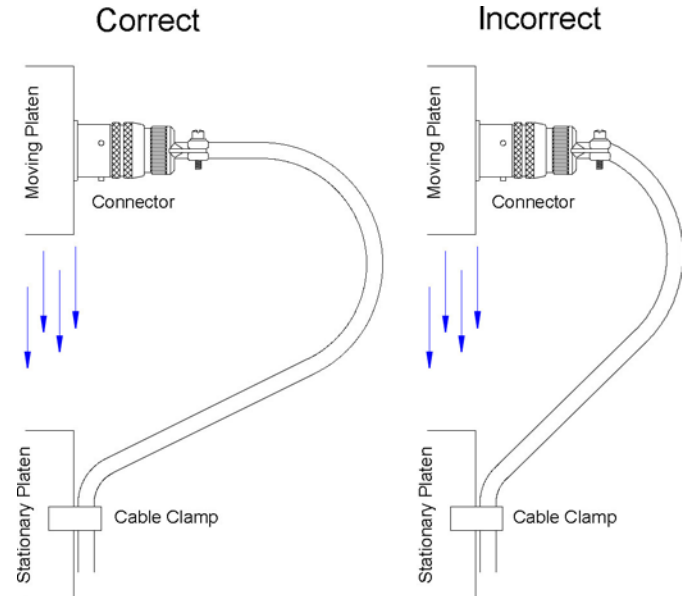

**Figure 22:** Retaining the Sensor Cable

**NOTE:** *If the sensor's cable becomes damaged during installation or on subsequent production runs, whereas the cable wires are accidentally cut or pulled out of the sensor body or connector, DO NOT try to re-solder the wires back together at your facility. Instead, send the sensor back to RJG to have the wires re-soldered and the sensor re-calibrated. Splicing and soldering a damaged cable may cause calibration errors.*

### In the Mold

Self-locking cable clips were included with your sensor order. These clips help to retain the sensor's cable in the mold. The clips will greatly reduce the risk of damage caused to the cable when the mold is reassembled. RJG recommends spacing the clips approximately 3" apart along the channel. Refer to Figures 9 and 12 for installation of the clips.

## Appendix F - Multiple Sensors in a Slot

If installing more than one sensor in the same slot, use the following equation for increasing the slot size:

Metric (mm)

(Slot Width \* Depth) must be greater than (# of cables \* 25.8)

English (inches)

(Slot Width \* Depth) must be greater than (# of cables \* 0.04)

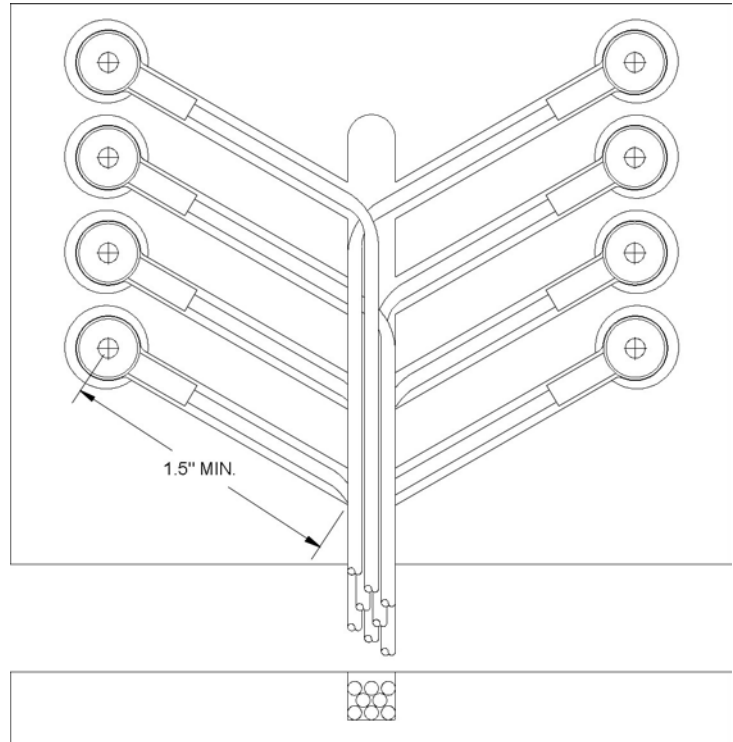

**Figure 23:** Multiple Sensors in a Slot

**NOTE:** *If the sensor cable must be bent to accommodate obstacles in the mold, there must be a 1.50" minimum clearance (from the center of the button towards the connector end) before the cable can be bent. This will ensure that the wires will not be pulled out of the button.*

## Sensor Selection Table for Under-The-Pin-Sensors

Nominal Pin Size	Pin Dia (in)	Expected Plastic Pressure (psi)			
		5000	10000	15000	20000
3/64	0.047	N/A	N/A	N/A	N/A
3/64 OS	0.052	N/A	N/A	N/A	N/A
1.5mm	0.059	N/A	N/A	N/A	55
1/16	0.063	N/A	N/A	46	61
1/16 OS	0.068	N/A	N/A	54	72
5/64	0.078	N/A	48	72	96
2.0mm	0.079	N/A	49	73	97
5/64 OS	0.083	N/A	54	81	108
3/32	0.094	N/A	69	104	138
2.5mm	0.098	N/A	76	114	152
3/32 OS	0.099	N/A	77	115	153
7/64	0.109	47	94	141	188
7/64 OS	0.114	51	103	154	206
3.0mm	0.118	55	110	164	219
1/8	0.125	61	123	184	245
3.2mm	0.126	62	125	187	249
1/8 OS	0.130	66	133	199	265
9/64	0.141	78	155	233	311
5/32	0.156	96	192	288	384
4.0mm	0.158	97	195	292	390
5/32 OS	0.161	102	204	307	409
4.2mm	0.165	107	215	322	429
11/64	0.172	116	232	348	464
3/16	0.188	138	276	414	552
3/16 OS	0.193	146	291	437	582
5.0mm	0.197	152	304	457	609
13/64	0.203	162	324	486	648
5.2mm	0.205	165	329	494	658
7/32	0.219	188	376	564	752
7/32 OS	0.224	197	393	590	787
15/64	0.234	216	432	647	863
6.0mm	0.236	219	438	657	876
B	0.238	222	445	667	890
C	0.242	230	460	690	920
6.2mm	0.244	234	468	701	935
D	0.246	238	475	713	951
1/4	0.250	245	491	736	982
1/4 OS	0.255	255	511	766	1021
F	0.257	259	519	778	1037
G	0.261	268	535	803	1070
17/64	0.266	277	554	831	1108
I	0.272	291	581	872	1162
J	0.277	301	603	904	1205
9/32	0.281	311	621	932	1243
9/32 OS	0.286	322	644	966	1288
L	0.290	330	661	991	1321
M	0.295	342	683	1025	1367

Nominal Pin Size	Pin Dia (in)	Expected Plastic Pressure (psi)			
		5000	10000	15000	20000
19/64	0.297	346	692	1038	1385
N	0.302	358	716	1074	1433
5/16	0.313	383	767	1150	1534
8.0mm	0.315	390	779	1169	1559
5/16 OS	0.318	396	792	1188	1583
8.2mm	0.323	409	818	1228	1637
P	0.323	410	819	1229	1639
21/64	0.328	423	845	1268	1691
Q	0.332	433	866	1299	1731
R	0.339	451	903	1354	1805
11/32	0.344	464	928	1392	1857
11/32 OS	0.349	478	956	1433	1911
23/64	0.359	507	1014	1522	2029
U	0.368	532	1064	1595	2127
3/8	0.375	552	1104	1657	2209
V	0.377	558	1116	1674	2233
3/8 OS	0.380	567	1134	1701	2268
W	0.386	585	1170	1755	2340
10.0mm	0.394	609	1217	1826	2435
X	0.397	619	1238	1867	2476
Y	0.404	641	1282	1923	2564
13/32	0.406	648	1297	1945	2593
13/32 OS	0.411	664	1329	1993	2657
7/16	0.438	752	1503	2255	3007
7/16 OS	0.443	769	1538	2307	3076
15/32	0.469	863	1726	2589	3452
12.0mm	0.472	876	1753	2629	3505
15/32 OS	0.474	882	1763	2645	3526
1/2	0.500	982	1963	2945	3927
1/2 OS	0.505	1001	2003	3004	N/A
14.0mm	0.551	1193	2385	3578	N/A
9/16	0.563	1243	2485	3728	N/A
5/8	0.625	1534	3068	N/A	N/A
16.0mm	0.630	1558	3116	N/A	N/A
11/16	0.688	1856	3712	N/A	N/A
18.0mm	0.709	1972	3945	N/A	N/A
3/4	0.750	2209	N/A	N/A	N/A
20.0mm	0.787	2435	N/A	N/A	N/A
7/8	0.875	3007	N/A	N/A	N/A
1	1.000	3927	N/A	N/A	N/A

	Slide	Cobra	Button
125 lb*	T-410	N/A	T-414
500 lb	T-405	T-425	T-412
2000 lb	T-406	T-426	T-413
4000 lb	N/A	N/A	T-445

\*Colors match the RJG standard color code for sensor caps.

### How to select a sensor

1. Locate the pin size that will be used with your RJG sensor by looking down on the row of the left side of the table.
2. Locate the maximum plastic pressure expected in the mold by looking across the column headings at the top of the table.
3. The value at the intersection of the row and column is the load (lb) that will be on the sensor.
4. Find the matching shade in the table on the lower right to find the recommended indirect sensor(s) for your application.

NOTE: RJG also has a selection of flush mount sensors for applications where an under-the-pin sensor is not practical.

## **RJG Product Disclaimer**

Inasmuch as RJG, Inc. has no control over the use to which others may put this material, it does not guarantee that the same results as those described herein will be obtained. Nor does RJG, Inc. guarantee the effectiveness or safety of any possible or suggested design for articles of manufacture as illustrated herein by any photographs, technical drawings and the like. Each user of the material or design or both should make his own tests to determine the suitability of the material or any material for the design, as well as the suitability of the material, process and/or design for his own particular use. Statements concerning possible or suggested uses of the materials or designs described herein are not to be construed as constituting a license under any RJG, Inc. patent covering such use or as recommendations for use of such materials or designs in the infringement of any patent.

RJG, Inc. is not responsible for the improper installation of this equipment, or any other equipment RJG manufactures.

Proper RJG equipment installation does not interfere with original equipment safety features of the machine. Safety mechanisms on all machines should never be removed.