

Date Stamps

CH-Series: Compact Height

Maximum mold temperature: 450° F (230° C)

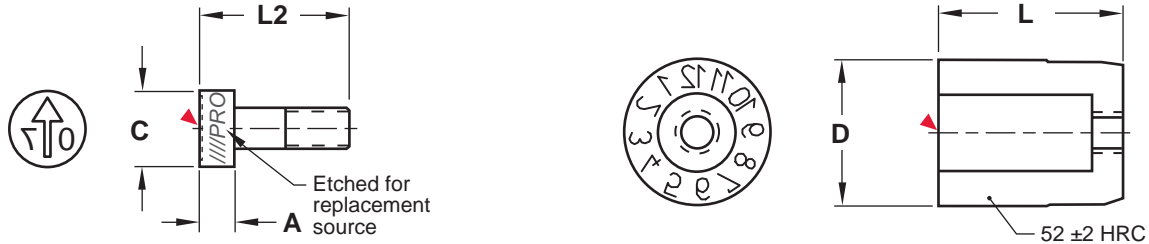

M 420 Stainless Steel **H** 50-54 HRC

▶ CAD insertion point

Nominal Ring O.D.	D		L		C		A		L2	
	mm	Inch	mm	Inch	mm	Inch	mm	Inch	mm	Inch
4	4	.1574	8	.315	2.2	.086	2	.078	8	.315
5	5	.1968	8	.315	3.1	.122	2	.078	8	.315
6	6	.2362	8	.315	3.1	.122	2	.078	8	.315
8	8	.3149	10	.394	4.4	.173	2.5	.098	10	.393
10	10	.3937	12	.472	5.2	.205	3	.118	12	.472
12	12	.4724	14	.551	6.2	.244	3	.118	14	.551
16	16	.6299	14	.551	8.2	.322	3.5	.137	14	.551
20	20	.7874	16	.630	11	.433	4.5	.177	16	.630

Engraving Depth:
 Numbers: .2mm (.007")
 Arrows: .4mm (.015")

To Order: Specify catalog number as shown below for the different style rings and plugs.

Ring Styles: Recessed Lettering

	Months Cat #: DC-Diam Ex.: DC05		A - M Cat #: DCA-Diam Ex.: DCA05
	Years Cat #: DCY-Diam — Starting Year Ex.: DCY05-07		N - Z Cat #: DCZ-Diam Ex.: DCZ05
	Days Cat #: DCL-Diam Ex.: DCL05		Blank Cat #: DC-Diam — B Ex.: DC05-B
	0 - 9 Cat #: DCN-Diam Ex.: DCN05		

Installation Guidelines:

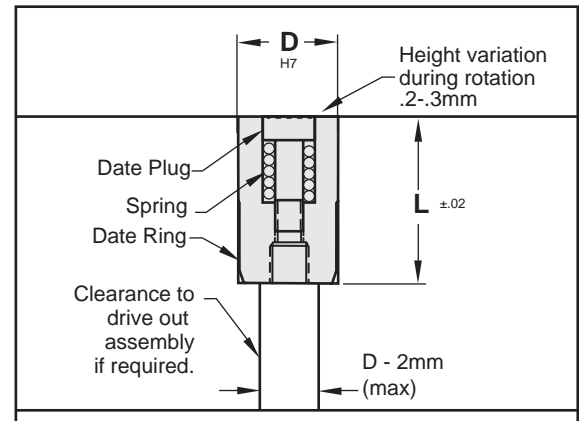

C www.procomps.com/customs

D www.procomps.com/design

Special configurations are available. Contact Customer Service for more information.

* Where years are specified, any year can be ordered by changing the suffix.

Example DCP05-08 or DCY05-09.

European dater delivery in 2 weeks maximum,
with shorter deliveries subject to availability.