

New! Traceability Marker

Patented Cumsa System

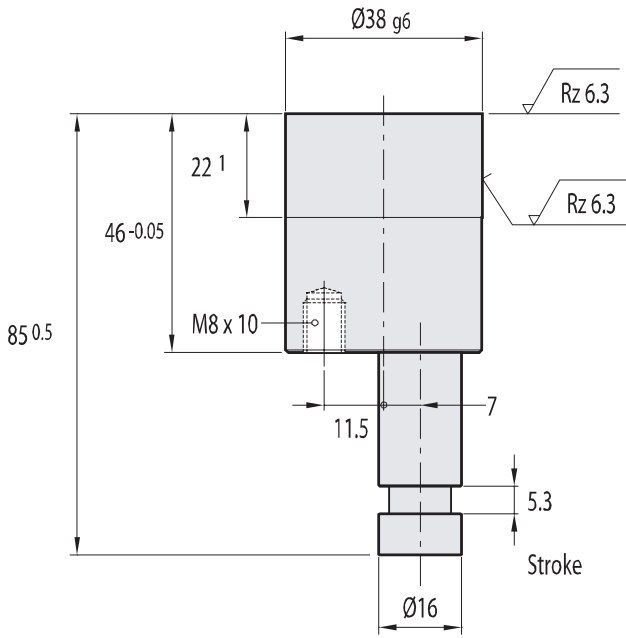

CATALOG NUMBER
NS 384616

What's Important

- Identify each plastic part with its own serial number during molding, without additional manual operations
- The serial number cannot be manipulated, thus, allowing total production control.

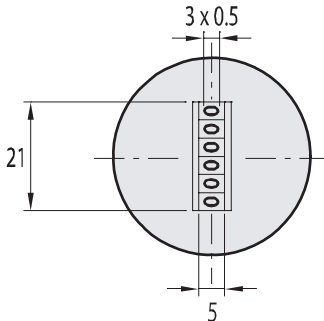

IMPORTANT:
We recommend the use of a magnetic stopper to limit the ejector plate stroke.

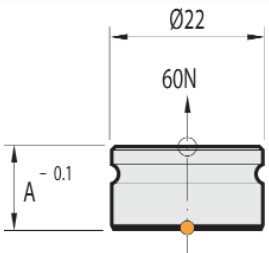
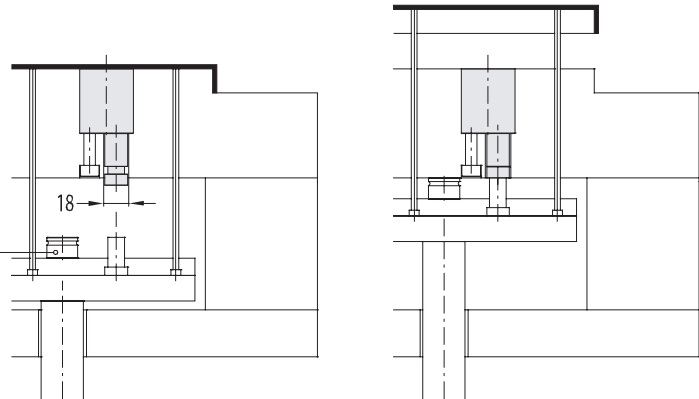

MAGNETIC STOPPERS	
CATALOG NUMBER	A
TM 102214	10
TM 122214	12.5
TM 152214	15
TM 202214	20

