

# Ejector Sleeves

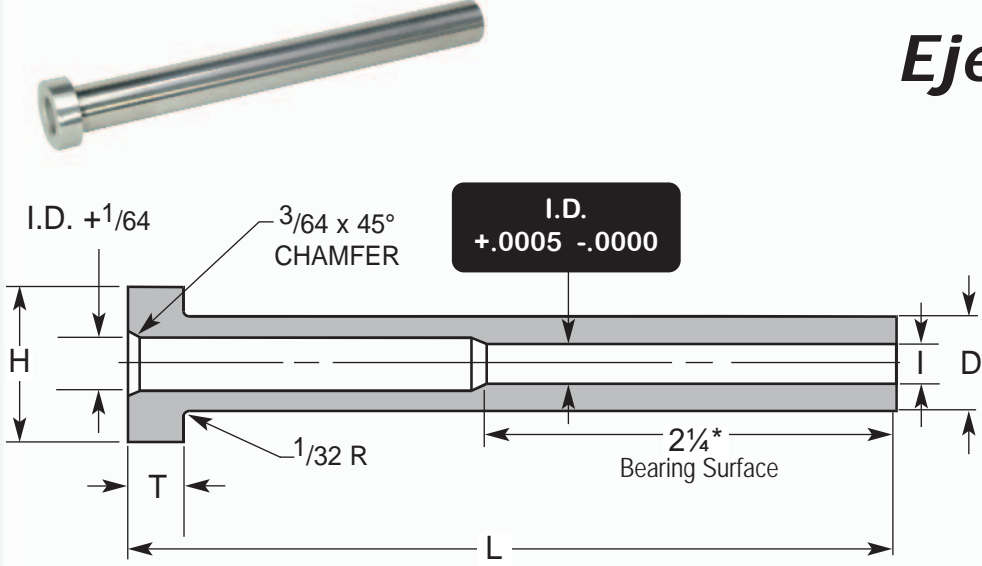

Tolerances	
Sleeve O.D. (D)	+0.000 -.001
Sleeve I.D. (I)	+0.0005 -.0000
Head Diameter (H)	+0.000 -.010
Head Thickness (T)	+0.000 -.002
Length (L)	+0.032 -.000

CATALOG NUMBER	I I.D.	D O.D.	H HEAD DIA	T HEAD THICK.	L = LENGTH													
					3"	4"	5"	6"	7"	8"	9"	10"	11"	12"	13"	14"		
SL13-*	3/32	3/16	3/8	3/16	.	.	.	.	.	.	.	.	.	.	.	.	.	
SL15-*	1/8	7/32	13/32	3/16	.	.	.	.	.	.	.	.	.	.	.	.	.	
SL17-	5/32	1/4	7/16	3/16	.	.	.	.	.	.	.	.	.	.	.	.	.	
SL21-	3/16	5/16	1/2	1/4	.	.	.	.	.	.	.	.	.	.	.	.	.	
SL23-	7/32	11/32	9/16	1/4	.	.	.	.	.	.	.	.	.	.	.	.	.	
SL25-	1/4	3/8	5/8	1/4	.	.	.	.	.	.	.	.	.	.	.	.	.	
SL29-	5/16	7/16	11/16	1/4	.	.	.	.	.	.	.	.	.	.	.	.	.	
SL33-	3/8	1/2	3/4	1/4	.	.	.	.	.	.	.	.	.	.	.	.	.	
SL37-	7/16	5/8	7/8	1/4	.	.	.	.	.	.	.	.	.	.	.	.	.	
SL39-	1/2	11/16	15/16	1/4	.	.	.	.	.	.	.	.	.	.	.	.	.	
SL41-	9/16	3/4	1	1/4	.	.	.	.	.	.	.	.	.	.	.	.	.	
SL45-	5/8	7/8	1 1/8	1/4	.	.	.	.	.	.	.	.	.	.	.	.	.	
SL47-	3/4	1	1 1/4	1/4	.	.	.	.	.	.	.	.	.	.	.	.	.	

- O.D. 65 - 74 Rc nitrided
- I.D. 65 - 74 Rc nitrided
- Etched for Easy Identification

\* SL13 & SL15 bearing length is 1-3/4" Add length to catalog number (i.e. SL25-5)



## .005 Oversize O.D. Ejector Sleeves

- O.D. 65 - 74 Rc nitrided
- I.D. 65 - 74 Rc nitrided
- Etched for Easy Identification

CATALOG NUMBER	+0005 -.0000 I I.D.	+000 -.001 D O.D.**	H HEAD DIA	T HEAD THICK.	L = LENGTH						
					4"	5"	6"	7"	8"	9"	10"
OSL13-*	3/32	.1925	3/8	3/16	.	.	.	.	.	.	.
OSL15-*	1/8	.2238	13/32	3/16	.	.	.	.	.	.	.
OSL17-	5/32	.2550	7/16	3/16	.	.	.	.	.	.	.
OSL21-	3/16	.3175	1/2	1/4	.	.	.	.	.	.	.
OSL25-	1/4	.3800	5/8	1/4	.	.	.	.	.	.	.
OSL29-	5/16	.4425	11/16	1/4	.	.	.	.	.	.	.
OSL33-	3/8	.5050	3/4	1/4	.	.	.	.	.	.	.

\* OSL13 and OSL15 bearing length is 1-3/4" \*\*O.D. size is +.005 over standard O.D. size Add length to catalog number (i.e. OSL25-5)

Home of the Hardened Throughout™ Pin

