

Sprue Bushings

The Sprue Bushing provides a seat at the spherical radius for the nozzle of the press. This provides a path for the material from the nozzle to the runner system.

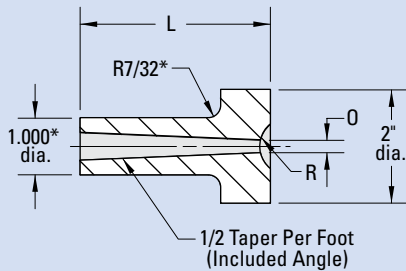

*For 88 & 812 mold base diameter is .750 and R equals 1/8

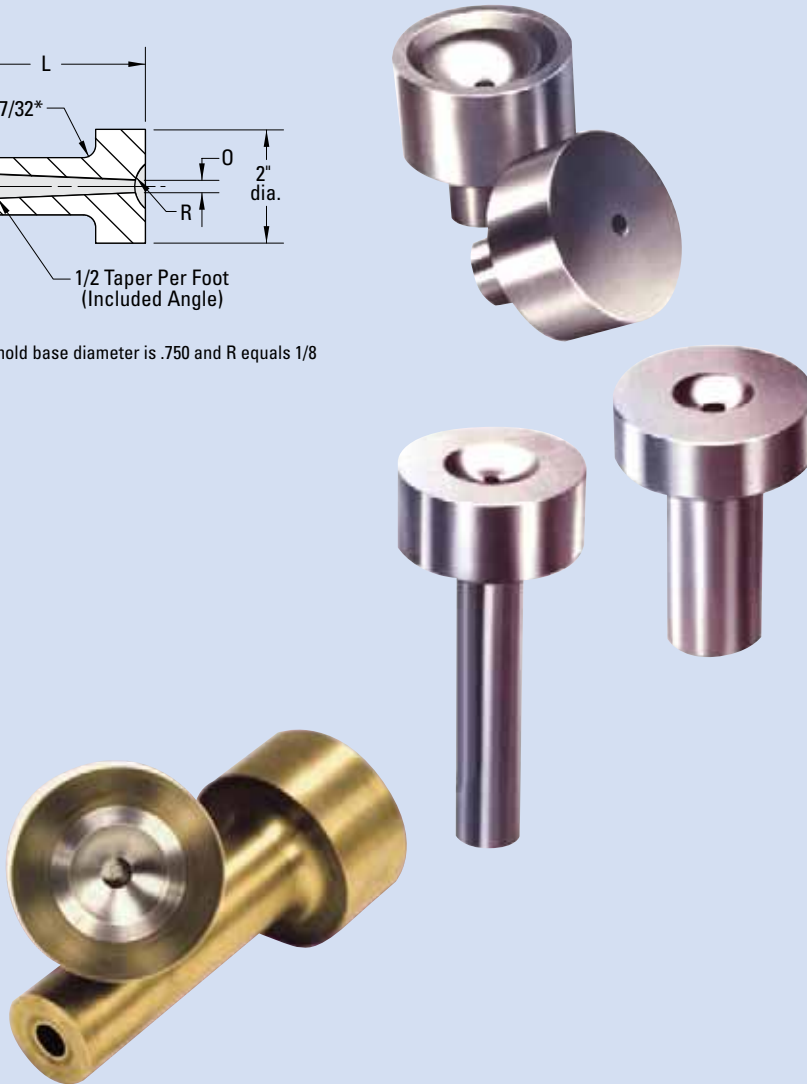

Features supplied as standard unless otherwise specified.

FOR QUOTING OR ORDERING, SPECIFY:

Sprue Bushing Series

Standard "B" or "U" (for 88 and 812 mold bases) Series or select any standard D-M-E sprue bushings including D-M-E high-performance sprue bushings.

O (Orifice) _____

R (Radius) _____

NOTE: Refer to D-M-E Mold Components catalog for more information on our complete line of sprue bushings.

Position/Omission:

Position on center Center

or relocate to

X _____ Y _____

Omit sprue bushing hole

Omit sprue bushing part