

Mini-Might™ Slide Retainers

(U.S. Patent No. 5,397,226)

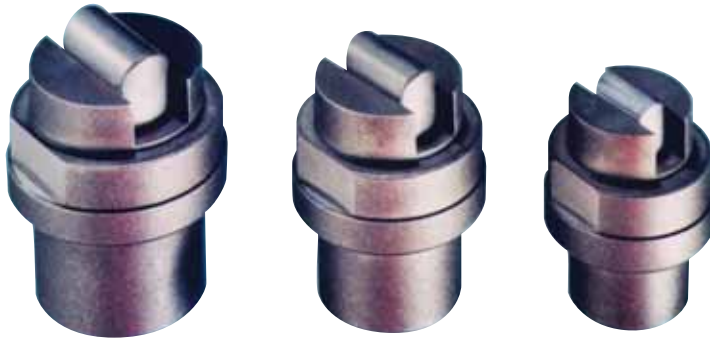

Installation Dimensions for Machining V-Groove in Slide

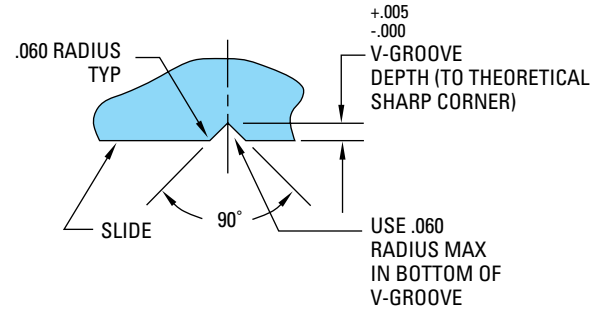

- Three sizes with retaining ratings for 10, 20 and 40 lbs.
- Small in size yet strong holding capacity
- Product design facilitates easy installation
- Slide can be removed without removing the slide retainer from the mold
- Self-contained design
- Line contact engagement

ITEM NUMBER	V-GROOVE DEPTH
PSR1000	.091
PSR2000	.153
PSR4000	.194

NOTE: See "Pocket Dimensions" for additional information.

Dimensional Information for Mini-Might™ Slide Retainers – PSR

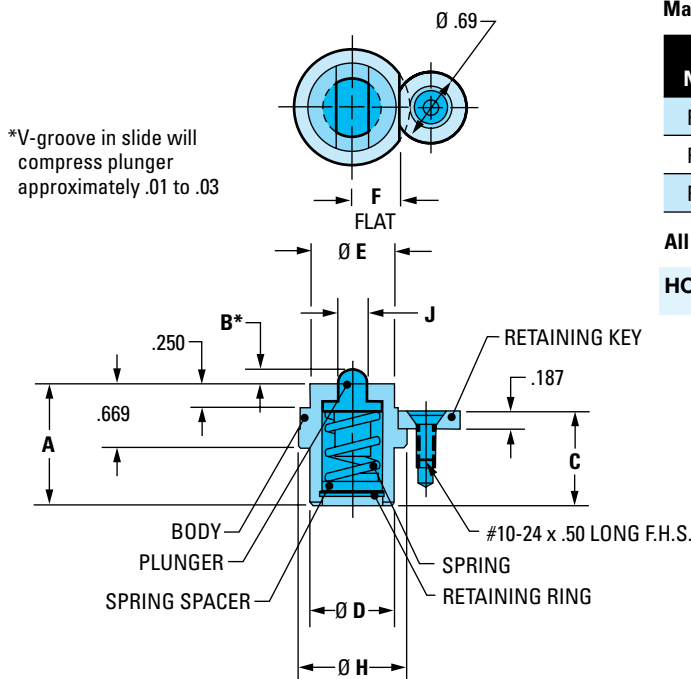

Material: Hardened H-13 Steel (Body and Plunger)

ITEM NUMBER	A	B	C	Ø D	Ø E	F FLAT	Ø H	J PLUNGER
PSR1000	1.08	.072	.795	.620	.630	.375	.866	.188
PSR2000	1.32	.121	1.035	.740	.748	.420	.984	.250
PSR4000	1.26	.149	.975	.870	.866	.468	1.102	.312

All items in stock.

HOW TO ORDER: Use Item Numbers in charts for ordering.

ITEM NUMBER	MAXIMUM RECOMMENDED HOLDING WEIGHT
PSR1000	10 POUNDS
PSR2000	20 POUNDS
PSR4000	40 POUNDS

†Each includes: slide retainer assembly, retaining key and #10-24 x .50 long flat head screw. Replacement parts are special order.

NOTE: See "Pocket Dimensions" for additional information.

Mini-Might™ Slide Retainers

Typical Application

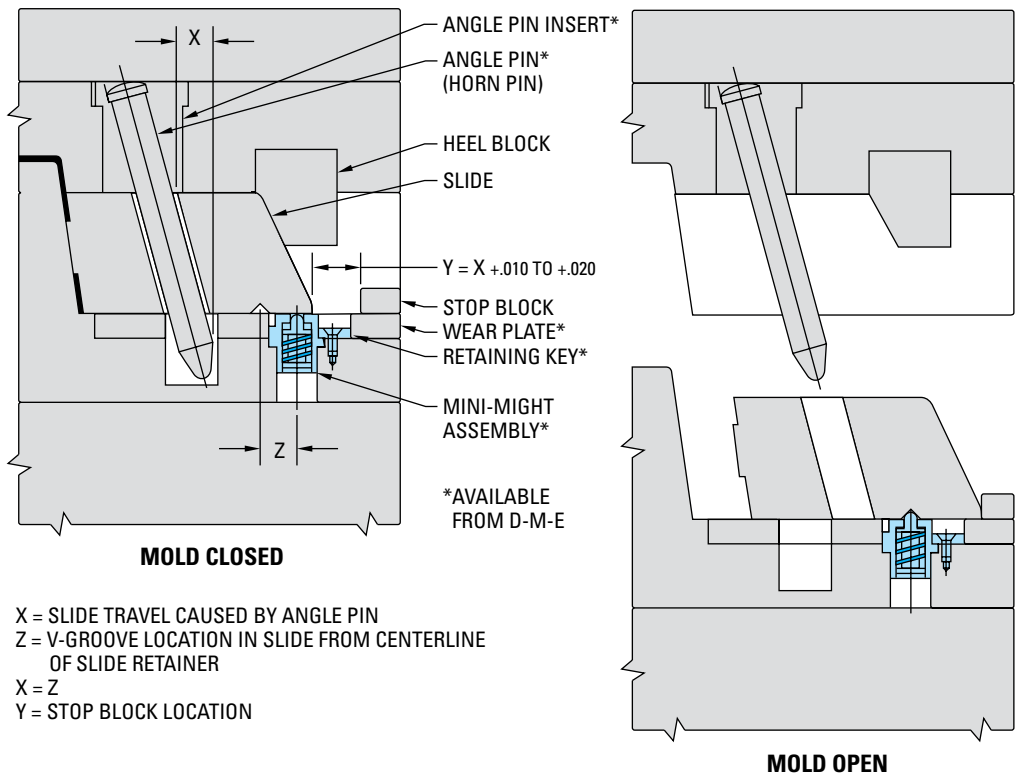

X = SLIDE TRAVEL CAUSED BY ANGLE PIN
 Z = V-GROOVE LOCATION IN SLIDE FROM CENTERLINE OF SLIDE RETAINER
 X = Z
 Y = STOP BLOCK LOCATION

NOTES:

1. Lubricate all metal-to-metal contact areas before first use and every 100,000 cycles (or more frequently as required). Use a good grade of moldmakers' non-melting type grease rated for the operating temperature to be encountered.
2. Replace compression spring every 1,000,000 cycles or as required.
3. Do not operate at temperatures exceeding 250°F.

Pocket Dimensions for Mini-Might™ Slide Retainers – PSR

NOTE: .500 thick wear plate can also be used to key and retain Mini-Might slide retainer instead of retaining key. Mold maker to machine to suit.

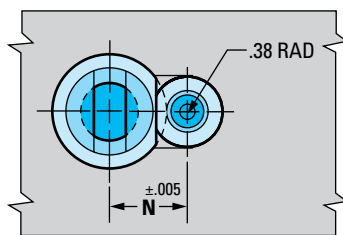

ITEM NUMBER	Ø K	Ø L	Ø M	N DIM
PSR1000	.625	.869	.94	.670
PSR2000	.750	.987	1.06	.715
PSR4000	.875	1.105	1.19	.763

All items in stock.

HOW TO ORDER:
 Use Item Numbers in charts for ordering.

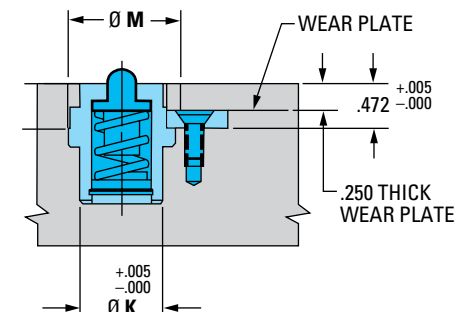
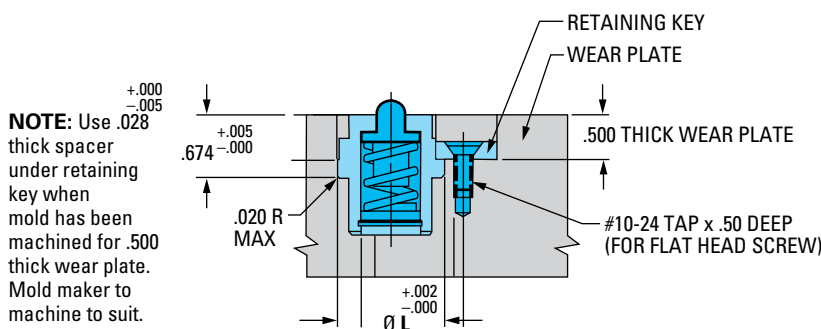

SmartLock® Slide Retainer and Limit Switch

(U.S. Patent No. 6,126,429)



The SmartLock® slide retainer and limit switch is designed for injection molders to provide switching and a slide detent in one unique package. The SmartLock locking function prevents premature slide movement during molded part ejection while the SPDT switch is simultaneously actuated.

The SmartLock slide retainer and limit switch has been tested for reliability over 10 million cycles without failure. Two or more switches may be used for larger molds, or molds with multiple slides. Increased safety and prevention of mold damage result when the SmartLock slide lock and limit switch is installed in a mold.

- Prevents damage caused by premature slide movement
- 17 to 27 pounds holding force – adjustable for optimum operation
- 175°F (79.4°C) standard temperature rating enables use for most molding applications
- Quality tested over 10 million cycles to provide long, dependable service
- Flush-mounted switch is shielded from damage by mounting inside a protective milled pocket
- Stripped and tinned 6 ft. wire leads make the switch ready to install without modification
- Mounting screws and wire clips supplied for neat and easy installation

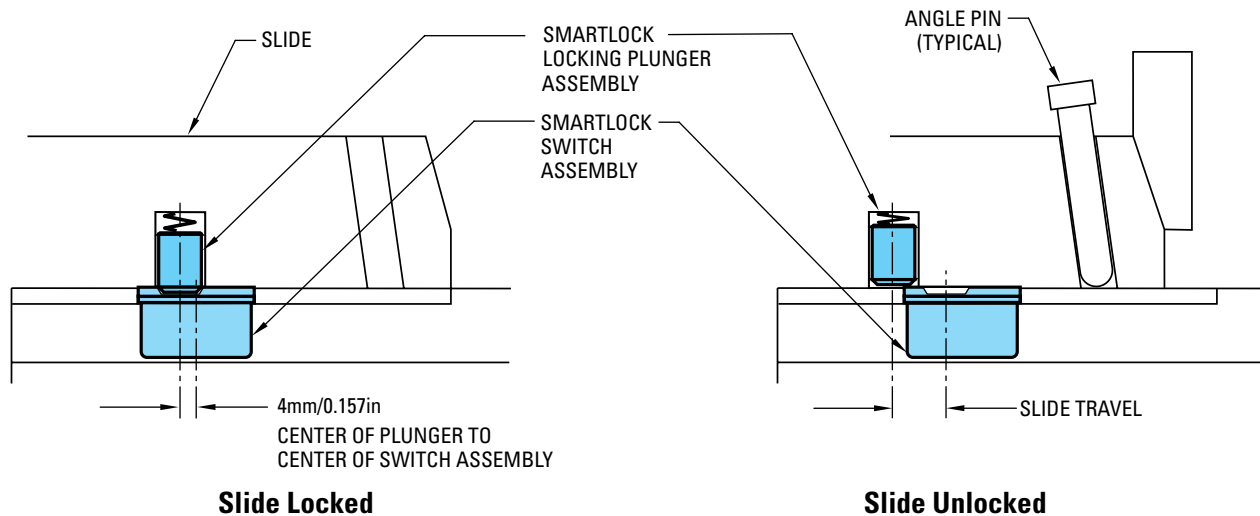

SmartLock Slide Retainer and Limit Switch – SLS 2220

NOTE: Please contact D-M-E for high-temperature applications.

SPECIFICATIONS		MATERIALS	
BREAK-AWAY FORCE	17 TO 27 LBS. (USER ADJUSTABLE)	SWITCH ASSEMBLY BODY	FIBERGLASS-REINFORCED NYLON
ELECTRICAL	250VAC/28VDC 4 AMPS INDUCTIVE 5 AMPS RESISTIVE REQUIRES 3-PIN CONNECTOR WITH MINIMUM RATINGS LISTED ABOVE	LOCKING PLATE	HARDENED STEEL
		LOCKING PLUNGER ASSEMBLY	HARDENED STEEL
OPERATING TEMPERATURE	175°F MAX. (79.4°C MAX.)	WIRE LEADS	22GA STRANDED, 3 CONDUCTOR, SHIELDED CABLE, 6 FT. (1.8M) LONG, ENDS STRIPPED AND TINNED
SWITCHING	SPDT		

ITEM NUMBER

SLS 2220

All items in stock.

HOW TO ORDER:
Use Item Numbers in charts
for ordering.

SmartLock® Slide Retainer and Limit Switch

The SmartLock switch is designed for use in very low power mold protection control circuits. It is not intended to switch heavy loads in power applications.



SmartLock includes 2 wire clamps.

Parts Included in SmartLock Slide Retainer and Limit Switch – SLS 2220

DESCRIPTION	QTY	DESCRIPTION	QTY
SWITCH ASSEMBLY	1	WIRE CLAMPS (.5" X .82" X .15" WITH .213" MOUNTING HOLE)	2
SWITCH MOUNTING SCREWS (#6-32 X 3/8" FLAT HEAD)	2	WIRE CLAMP SCREWS (#10-24 X 1/2" BUTTON HEAD)	2
LOCKING PLUNGER ASSEMBLY	1	INSTRUCTION SHEET	1

Rated Current vs. Steel Temperature – SLS 2220

AMPS	°F	°C
5.0	85	29.4
4.0	120	49.0
3.0	155	68.3
2.0	175	79.4

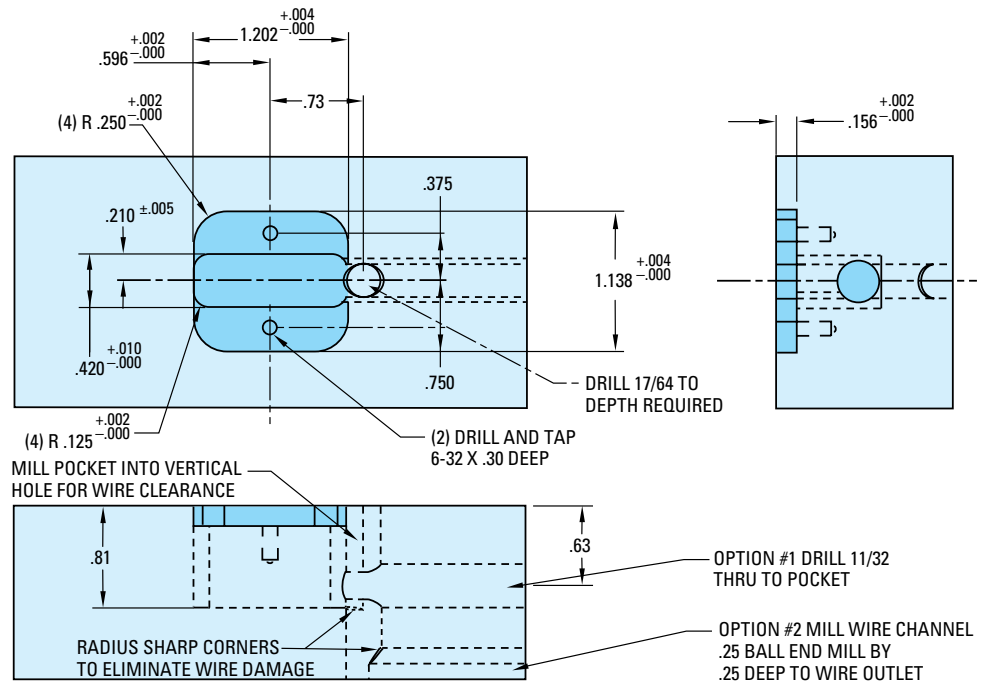

Suggested machining and wire routing.

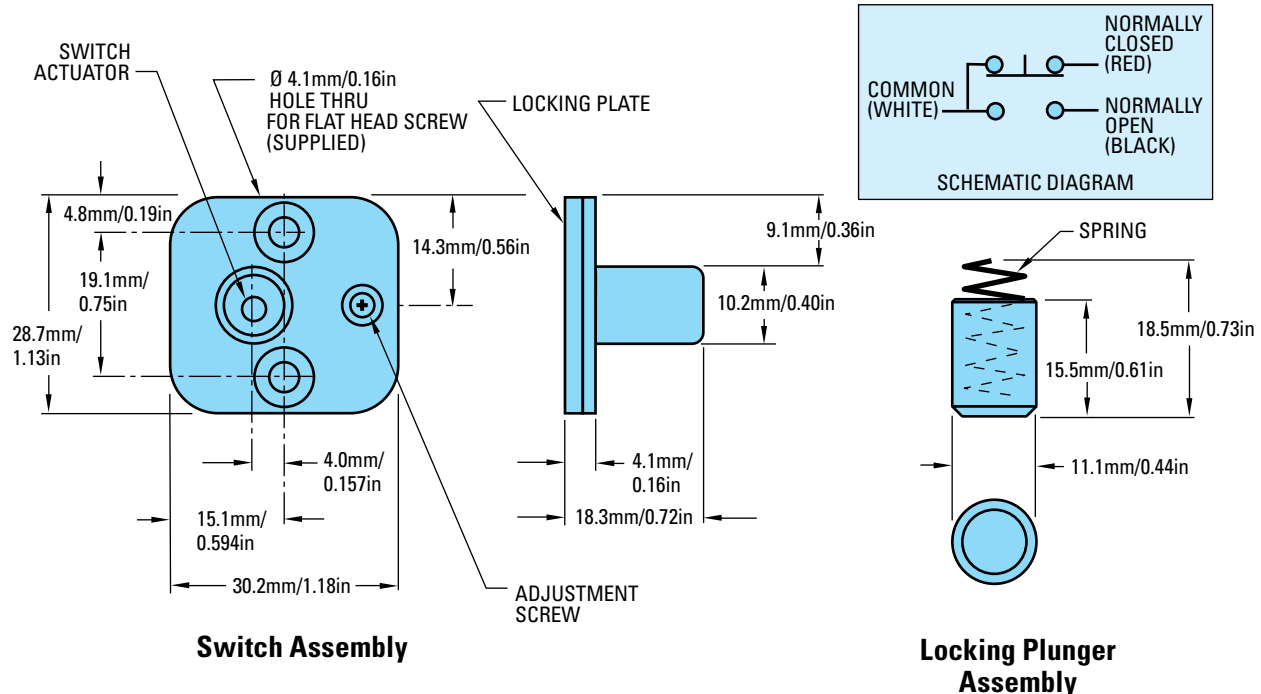

Slide Retainer Assemblies

The D-M-E Slide Retainer provides a compact and economical means of slide retention, which makes obsolete the cumbersome external spring or hydraulic methods. Its simple and positive operation makes it equally suitable for new tooling design or retrofitting existing molds. Available in three sizes with increasing weight-holding capacities, the Slide Retainers can be used individually or in multiples for larger or heavier slides.

Generally mounted behind and below the slide (see drawing at right), the D-M-E Slide Retainer is a compact unit that can be entirely contained within the mold. Interference with machine tie bars or safety gates is no longer a problem. (It can even be installed completely underneath the slide if space is limited.)

As the mold opens, the dowel pin installed in the slide positively locks into the retainer until disengaged by the mold's closing action. The custom-designed spring placed crosswise in the retainer maintains the force required to keep the dowel pin in the jaws when the mold is open.

The Slide Retainer is designed with a generous lead-in at the jaw opening so the dowel pin will enter the jaws even if there is a slight misalignment between the retainer and the pin.

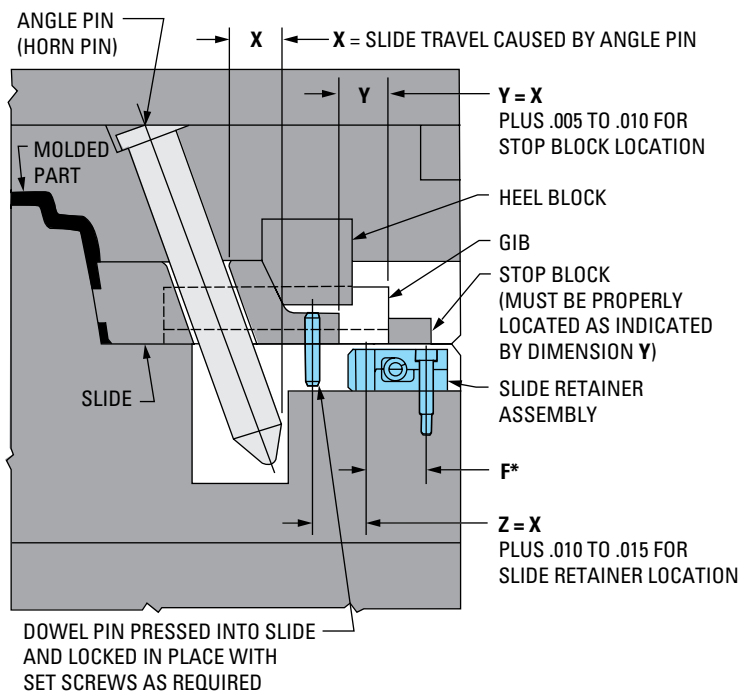

NOTE:
To prevent the dowel pin from contacting and applying pressure against the back of the retainer jaw (which could cause bending or shearing of the dowel pin or hold-down shoulder screw) the installation dimensions shown on these pages are recommended.

Slide Action Components | Slide Retainer Assemblies

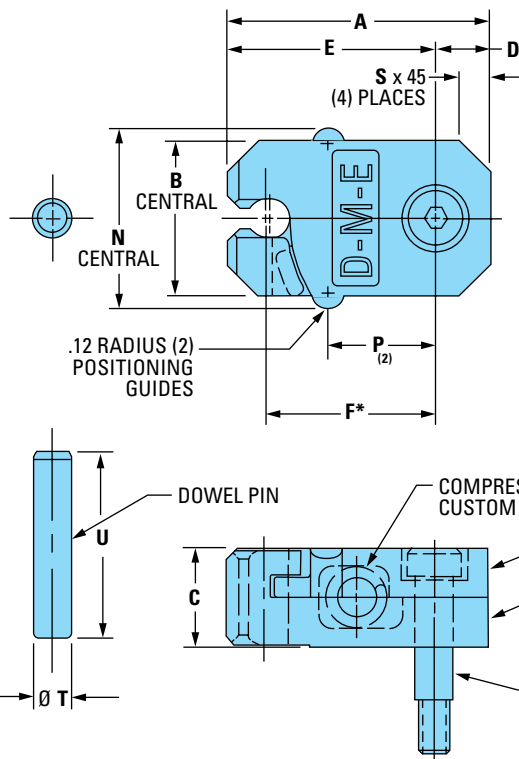

Slide Retainer Assemblies – PSL

Material: Investment Cast from 8620 steel
Hardness: Case-Hardened 58-62 HRC



U.S. Patent No. 4,961,702

ITEM NUMBER	A	B	C	D	E	F*	N	P	S	T	U
PSL0001	1.50	.76	.63	.27	1.23	.980	.94	.61	.14	.250	1.25
PSL0002	2.13	1.26	.79	.44	1.69	1.375	1.44	.88	.25	.312	1.50
PSL0003	3.38	1.76	1.18	.75	2.63	2.125	1.94	1.57	.38	.375	2.25

* Dimension F, the distance from dowel pin centerline at end of slide travel and centerline of shoulder screw, is important. Overtravel of dowel pin beyond clearance provided at back of jaw area could result in damage to retainer.

ITEM† NUMBER	MAXIMUM RECOMMENDED HOLDING WEIGHT
PSL0001	22 POUNDS
PSL0002	44 POUNDS
PSL0003	88 POUNDS

† Includes top and bottom jaw plate, compression spring, shoulder screw with thread locking element and dowel pin.

All items in stock.

HOW TO ORDER:
Use Item Numbers in charts for ordering.

Slide Retainer Installation Guidelines

Pocket Dimensions/Installation Guidelines

(Slide Retention Application Shown)

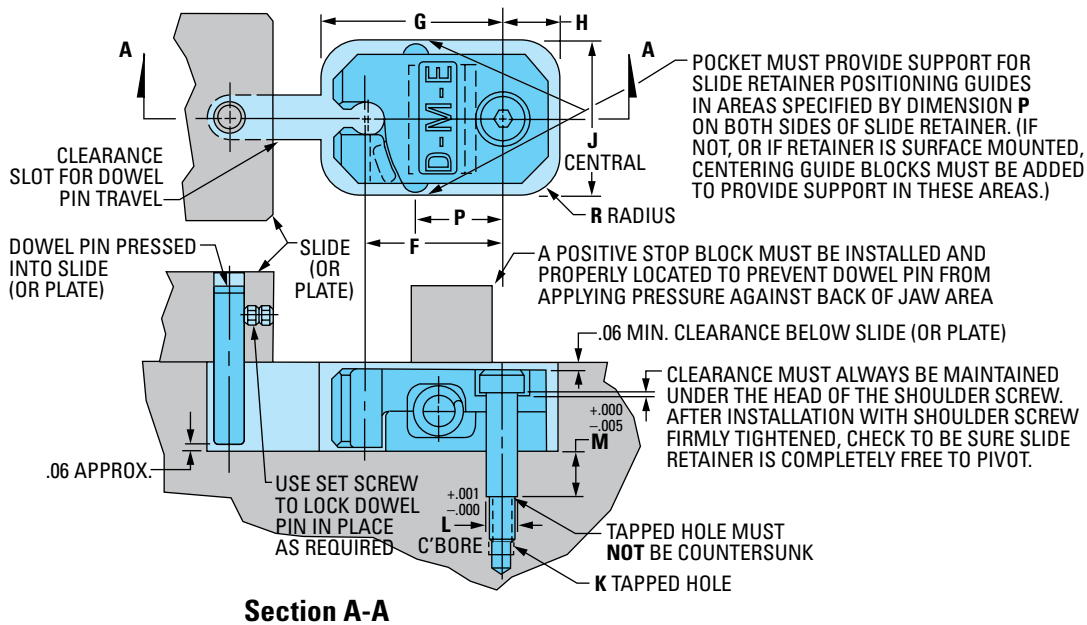

ITEM NUMBER	F	P	G	H	J	R RAD	K TAPPED HOLE AND TAP DEPTH BELOW C'BORE	L C'BORE	M C'BORE DEPTH
PSL0001	.980	.61	1.35	.39	1.00	.31	#10-24 x .50 DEEP	.249	.310
PSL0002	1.375	.88	1.81	.56	1.50	.37	1/4-20 x .56 DEEP	.3115	.430
PSL0003	2.125	1.57	2.75	.88	2.00	.50	5/16-18 x .62 DEEP	.374	.580

NOTES:

1. Dimension F, the distance from dowel pin centerline at end of slide travel and centerline of shoulder screw, is important. Overtravel of dowel pin beyond clearance provided at back of jaw area could result in damage to retainer.
2. Lubricate all metal-to-metal contact areas before first use and every 100,000 cycles (or more frequently as required). Use a good grade of moldmakers' non-melting type grease rated for the operating temperature to be encountered.
3. **Do not operate at temperatures exceeding 225°F.**
4. If two or more retainers are used, mount them uniformly to provide a balanced operation. Retainer sizes should not be mixed in a multiple retainer application.
5. Surface to which retainer is mounted should not prevent retainer from pivoting freely.
6. Replace retainer assembly and/or dowel pin when total wear in jaw area or on dowel pin exceeds .010.
7. Replace compression spring every 1,000,000 cycles or as required, following procedures packaged with retainer.

Retrofit Data for Molds with Previous Design Slide Retainers

ITEM NUMBER	K TAPPED HOLE AND TAP DEPTH BELOW C'BORE	L C'BORE	M C'BORE DEPTH	P	T** REF ONLY	FOR REPLACEMENT OF SLIDE RETAINER ITEM NUMBER
PSL0001	#10-24 x .50 DEEP	.249	.310	.61	.620	MRT-22
PSL0002	1/4-20 x .56 DEEP	.3115	.430	.88	.875	MRT-44
PSL0003	5/16-18 x .62 DEEP	.374	.580	1.57	1.325	MRT-88

**Dimension T is for reference only. See charts and application drawings to determine specific installation dimensions.

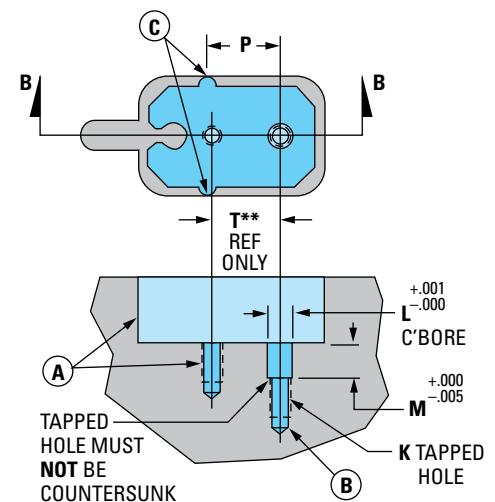

NOTES:

- A. Existing pocket and tapped hole for previous slide retainer (MRT-22, 44 or 88).
- B. Drilling, tapping and counterboring for shoulder screw at new location is required per drawing and chart dimensions.
- C. Existing pocket must provide support for retainer positioning guides in areas designated by dimension P or centering guide blocks must be added.

HOW TO ORDER: Use Item Numbers in charts for ordering.

All items in stock.