

Slide Clip

Patented Cumsa System

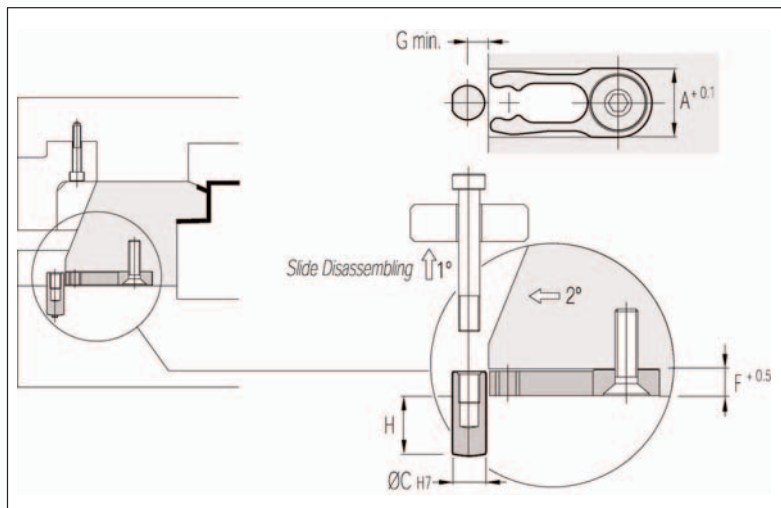
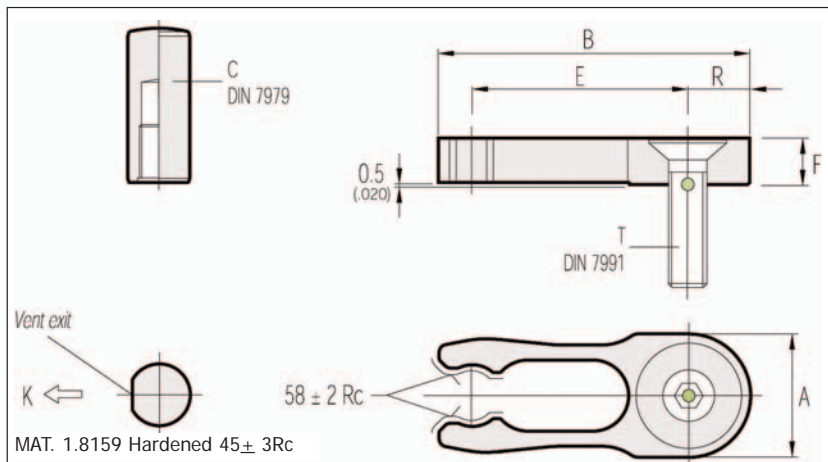

What's Important

- Simple Compact Design
- Easy Installation
- Minimum space for installation and access

CATALOG NUMBER	A	B	C	E	F	G	H	K (*)	R	T	MAX. WEIGHT
RC 123006	12	30	6 X 20	21	5	4	16	5 Kg.	6	M5 X 16	4 Kg.
RC 164008	16	40	8 X 20	28	6	5	15	7 Kg.	8	M6 X 25	6 Kg.
RC 205010	20	50	10 X 24	34	8	6	17	14 Kg.	10	M8 X 30	12 Kg.
RC 246012	24	60	12 X 32	42	10	7	23	21 Kg.	12	M10 X 40	18 Kg.
RC 328012	32	80	16 X 40	56	12	9	27	28 Kg.	16	M12 X 50	25 Kg.
RC 328016	32	80	16 X 40	56	16	9	25	38 Kg.	16	M12 X 50	32 Kg.

(*) The "K" value is the approximate force required to release the retainer.