

# Date Inserts

## For Plastic Molds

Patented Cumsa System

Month	Insert	Day	Shift	Year	Diagram			
MONTH	CENTER INSERT	DAY	SHIFT	YEAR	A	C	J	L
DS 0422-	DP 2275-		DS 04-03	DS 04-Y	4	2.2	7.5	12*
DS 0530-	DP 3075-	DS 05-31L	DS 05-03	DS 05-Y	5	3.0	7.5	12*
DS 0632-	DP 3217-	DS 06-31L	DS 06-03	DS 06-Y	6	3.2	17.0	20
DS 0847-	DP 4717-	DS 08-31L	DS 08-03	DS 08-Y	8	4.7	17.0	20
DS 1057-	DP 5717-	DS 10-31L	DS 10-03	DS 10-Y	10	5.7	17.0	20
DS 1267-	DP 6717-	DS 12-31L	DS 12-03	DS 12-Y	12	6.7	17.0	20
DS 1687-	DP 8717-	DS 16-31L	DS 16-03	DS 16-Y	16	8.7	17.0	20
DS 20107-	DP 10717-	DS 20-31L	DS 20-03	DS 20-Y	20	10.7	17.0	20

NOTE: \* Length changed from 10mm to 12mm. Mold operating temperature should not exceed 150°C (300°F)  
When ordering, add year to the end of the part number (i.e. DS 0632-03) or for assembly with arrow only (i.e. DS 0632)

Tolerances Inches								
DATE CODE	4 mm	5 mm	6 mm	8 mm	10 mm	12 mm	16 mm	20 mm
	.1575	.1969	.2362	.3150	.3937	.4724	.6299	.7874
A DIAMETER	+0.005	+0.005	+0.005	+0.006	+0.007	+0.007	+0.007	+0.008
	+0.002	+0.002	+0.002	+0.002	+0.003	+0.003	+0.003	+0.003
L LENGTH	+0.000	+0.000	+0.000	+0.000	+0.000	+0.000	+0.000	+0.000
	-0.002	-0.002	-0.002	-0.002	-0.002	-0.002	-0.002	-0.002

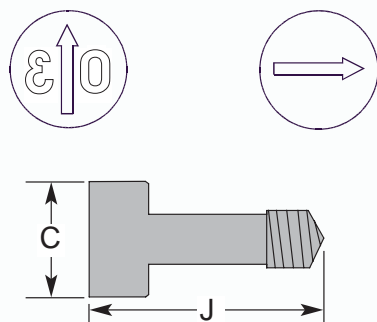

Engraving Depth Inches			
SIZE	CHARACTERS	ARROW HEAD	ARROW BODY
3 mm	.004 - .008	.016 - .020	.016 - .020
4 - 5 mm	.004 - .006	.016 - .020	.016 - .022
6 mm	.004 - .008	.016 - .020	.016 - .020
8 mm	.006 - .010	.016 - .020	.016 - .020
10 - 16 mm	.008 - .012	.020 - .024	.020 - .024
20 mm	.008 - .012	.020 - .024	.020 - .024

Center Insert With Arrow & Year		
CATALOG NUMBER	C	J
DP 2275-	2.2	7.5
DP 3075-	3.0	7.5
DP 3217-	3.2	17.0
DP 4717-	4.7	17.0
DP 5717-	5.7	17.0
DP 6717-	6.7	17.0
DP 8717-	8.7	17.0
DP 10717-	10.7	17.0

When ordering, add year to the end of the part number (i.e. DP 3217-03)

