

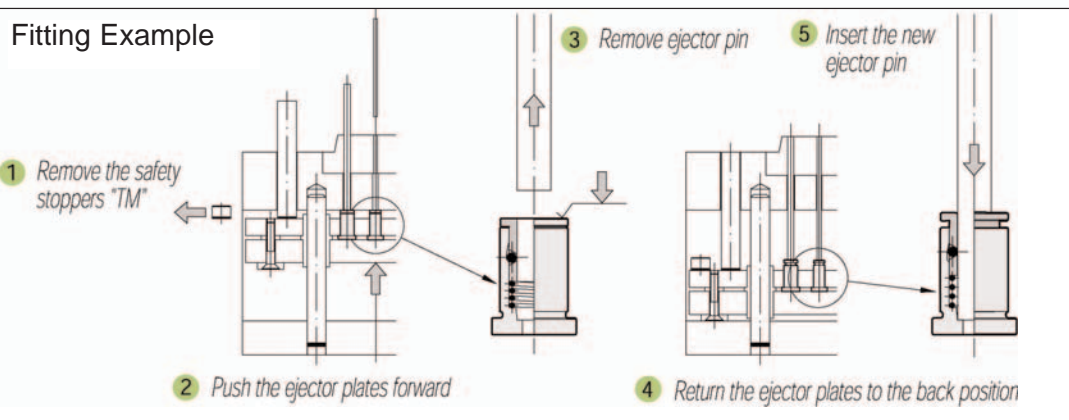

Ejector Pin Base

Patented Cumsa System

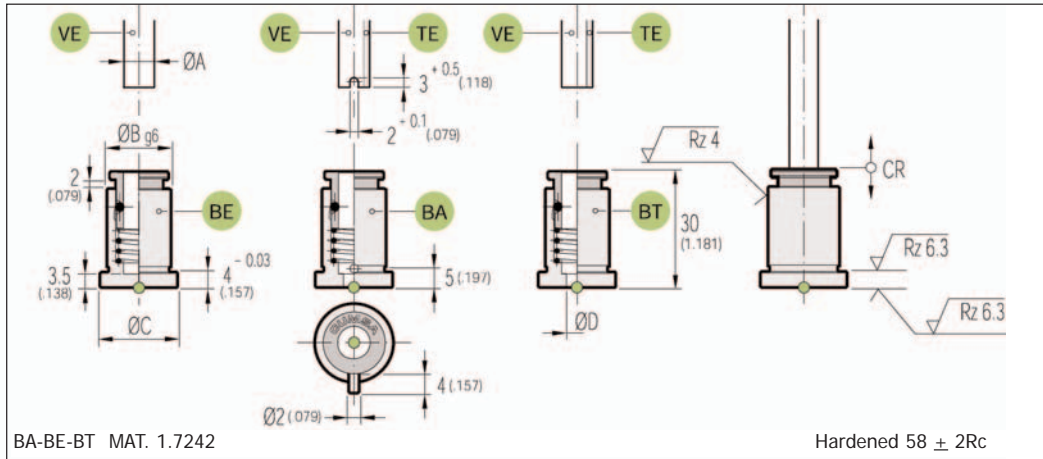

What's Important

- **Remove Pin from Parting Line**
- Incorporates a unique locking design that holds the ejector pin in place until the top collar is compressed
- Compact Design
- Pins can be replaced from the front of the mold, eliminating the need to disassemble

CATALOG NUMBER			A	B	C	D	CR (N)
BE 031115	-	-	3	11	15		≥ 2,550
BE 041216	-	-	4	12	16		≥ 2,500
BE 051317	-	-	5	13	17		≥ 3,800
-	BA 061418	BT 061418	6	14	18	3.5	≥ 3,800
-	BA 081620	BT 081620	8	16	20	5.5	≥ 5,100
-	BA 101822	BT 101822	10	18	22	7	≥ 6,400
-	BA 122024	BT 122024	12	20	24	9	≥ 7,600