

JIS Metric Step Pins

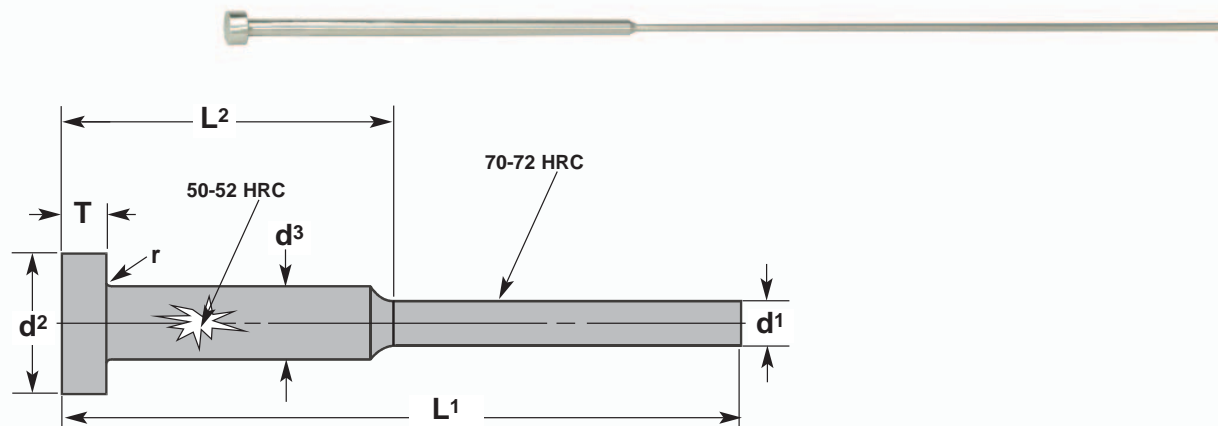

TYPE	JMS
MATERIAL	H-13

Tolerances mm	
Pin Diameter (d1)	-0.01 -0.02
Shoulder Diameter (d3)	-0.01 -0.02
Head Diameter (d2)	0.0 -0.2
Head Thickness (T)	0.00 -0.05
Length (L2)	+3.0 +1.0

CATALOG NUMBER	d1 PIN DIA	d2 HEAD DIA	d3 SHLD DIA	T HEAD THICK	L1	L2	L1	L2
					150	50	200	70
JMS-10-3-	1.0	6	3.0	4	•	•	•	•
JMS-12-3-	1.2	6	3.0	4	•	•	•	•
JMS-12-3-	1.2	6	3.0	4	•	•	•	•
JMS-15-3-	1.5	6	3.0	4	•	•	•	•
JMS-15-3-	1.5	6	3.0	4	•	•	•	•
JMS-20-4-	2.0	8	4.0	6	•	•	•	•
JMS-20-4-	2.0	8	4.0	6	•	•	•	•
JMS-25-4-	2.5	8	4.0	6	•	•	•	•
JMS-25-4-	2.5	8	4.0	6	•	•	•	•

* NOTE: Add overall length to end of catalog number i.e. JMS-12-3-200